

NEW! Signet 2552 Metal Magmeter Flow Sensor



Features

- Patented* Magmeter technology
- Easy to remove and re-install during maintenance
- Hot-tap version for installation and service without system shutdown
- NPT or ISO threads
- Optional detachable waterproof cable
- Three output choices: frequency, digital (S³L), or 4 to 20 mA
- Bi-directional flow
- No moving sensor parts
- Adjustable insertion for large pipe sizes up to DN 1200 (48 in.)
- Empty pipe detection
- Flow rate range 0.05 to 10 m/s (0.15 to 33 ft/s)
- Measurement in dirty and high solids content liquids

Description

The Signet 2552 Magmeter Flow Sensor is a heavy duty, high performance sensor in an adjustable-insertion configuration that can be used with a ball valve for hot-tap installations. This insertion style flow sensor has no moving parts and is constructed of corrosion-resistant materials to provide long-term reliability with minimal maintenance costs.

The 2552 is versatile and simple-to-install, delivering reliable flow measurement over a wide dynamic range in pipe sizes ranging from DN40 to DN1200 (1.5 to 48 inches). Signet 2552 Magmeters offer a variety of output options compatible with Signet

flow instrumentation that feature a frequency or digital (S³L) output. The blind transmitter (4 to 20 mA output) or digital sensor interface is available for long distance signal transmission.

The empty pipe detection features a zero flow output when the electrodes are not completely wetted. The frequency output is bi-directional while the 4 to 20 mA output can be set for uni- or bi-directional flow. The 4 to 20mA output is factory spanned and can be changed using the PC compatible accessory set-up tool.

System Overview

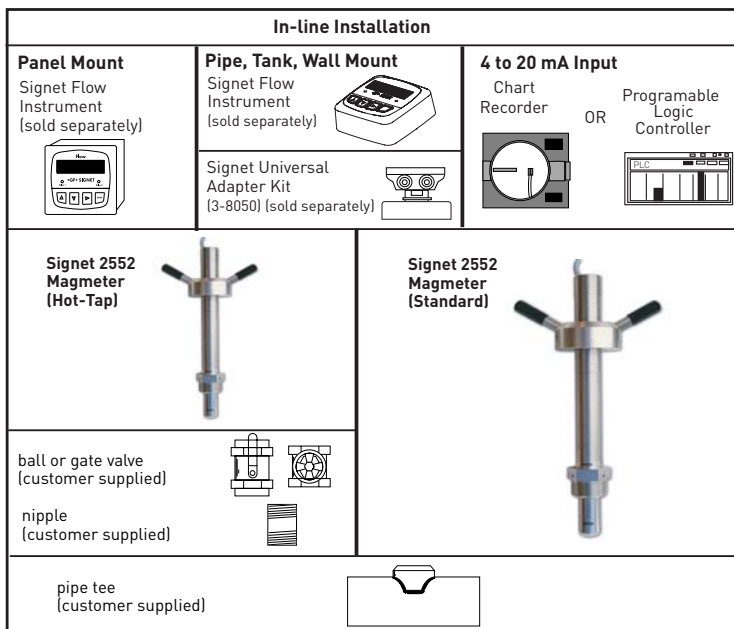

Applications

- Municipal Water Distribution
- Water Inlets to Process Plants
- Surface, Ground, and Ocean Water
- Chemical Processing
- Water and Wastewater Monitoring
- Industrial Water Distribution



Dimensions

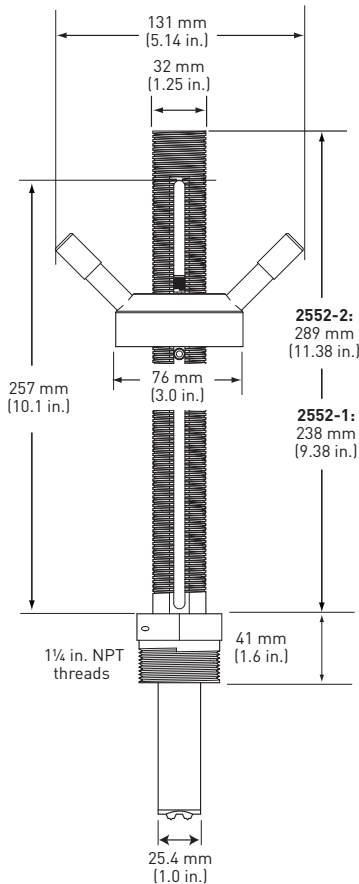

Specifications

Wetted Materials:

- 316L Stainless Steel body and electrodes
- PVDF Insulator
- O-rings: FPM (standard)
- Cable: 4-cond + shield, PVC jacket (Fixed cable models) or Watertight Rubber cable assembly with NEMA 6P connector

Power Requirements

- 4 to 20 mA: 21.6 to 26.4 VDC, 22.1 mA maximum
- Frequency: 4.5 to 26.4 VDC, 15 mA maximum
- Digital (S³L): 4.5 to 6.5 VDC, 15 mA maximum
- Reverse polarity and short circuit protected

Performance

Pipe size range:
DN40 to DN1200 (1.5 in. to 48 in.)

Flow Range

- Minimum: 0.05 m/s (0.15 ft/s)
- Maximum: 10 m/s (33 ft/s)

Linearity: $\pm(1\% \text{ reading} + 0.01 \text{ m/s})$
 $\pm(1\% \text{ reading} + 0.033 \text{ ft/s})$

Repeatability: $\pm 0.5\%$ of reading @ 25°C
Minimum Conductivity: 20 $\mu\text{S/cm}$

Electrical

Current output (4 to 20 mA)

- Programmable and reversible
- Loop Accuracy: 32 μA max. error (@ 25°C @ 24 VDC)
- Temp. drift: $\pm 1 \mu\text{A}$ per °C max.
- Power supply rejection: $\pm 1 \mu\text{A}$ per V
- Isolation: Low voltage < 48 VAC/DC from electrodes and auxiliary power
- Maximum cable: 300 m (1000 ft.)
- Max. Loop Resistance: 300 Ω
- Error condition: 22.1 mA

Electrical (continued)

Frequency output:

- Compatible with Signet 5075, 5500, 5600, 8550 and 8900
- Max. Pull-up Voltage: 30 VDC
- Short Circuit Protected: $\leq 30 \text{ V @ } 0\Omega$ pull-up for one hour
- Reverse Polarity Protected to -40 V for 1 hour
- Overvoltage Protected to +40 V for 1 hour
- Max. Current Sink: 50 mA, current limited
- Maximum cable: 300 m (1000 ft.)

Digital (S³L) Output:

- Compatible with Signet 8900
- Serial ASCII, TTL level 9600 bps
- Maximum cable: Application dependent (See 8900 manual)

Max. Temperature/Pressure Rating

Storage Temperature:

-15°C to 70°C (5°F to 158°F)
in non-icing conditions

Operating Temperature

- Ambient: -15°C to 70°C (5°F to 158°F) in non-icing conditions
- Media: -15°C to 85°C (5°F to 185°F)

Maximum Operating Pressure

20.7 bar @ 25°C (300 psi @ 77°F)

Hot-Tap Installation Requirements

- Maximum Installation Pressure: 20.7 bar (300 psi)
- Maximum Installation Temp.: 40°C (104°F)

Hot -tap installation at temperatures that are greater than 40°C or with hazardous liquids are not permitted with this product.

Standards and Approvals

- CE
- U.S. Patent No.: 7,055,396 B1
- Fixed cable: NEMA 6 (IP67)
- Watertight connector: NEMA 6P (IP68)
- EN 61326: Immunity and Emissions for Control Equipment

Sensor Selection Guide

The 2552 Magmeter can be installed into a variety of pipe sizes ranging from DN50 to DN1200 (2 in. to 48 in.). Follow the steps below to ensure that you choose the right sensor for your application.

Step 1: Determine how the sensor will be installed

A. For standard (no Hot-Tap) installations:

The height of the weldolet (threadolet) and pipe adapter(s) should be determined before the sensor is purchased.

- For retrofit installations, the stack height, or "A" dimension (see Fig. 1), is the overall height from the top of the pipe to the highest point of the stack before the sensor is connected.
- For new installations, Signet recommends a weldolet (threadolet) and an adapter to accommodate the 1.25 in. sensor process threads. The stack height, or "A" dimension (see Fig. 1), is the overall height from the top of the pipe to the highest point of the stack.

B. For Hot-Tap installations:

The stack height of the ball valve, nipple weldolet (threadolet) and pipe adapters should be determined before the sensor is purchased.

- For retrofit installations, the ball valve must be at least a 1.25 in. full port valve. The stack height, or "A" dimension (see Fig. 2), is the overall height from the top of the pipe to the top of the ball valve, or the top of the highest point of the stack before the sensor is connected.
- For new installations, Signet recommends a 1.25 in. full port ball valve, a short nipple and a weldolet (threadolet). The stack height or "A" dimension (see Fig. 2) is the overall height from the top of the pipe to the top of the ball valve.

Step 2: Determine how the sensor will be installed

Once the "A" dimension is determined, go to the sensor selection table and find your "A" dimension on the left column. Then, find the appropriate pipe size at the top of the chart. These two factors will determine which sensor is best suited for your installation.

Max. "A" Dimension		Pipe Size																											
		Inch	1.5 to 2		2.5	3 - 3.5		4	5	6 - 8		10	12 - 14		16	18	20	22	24	26 - 28		30 - 32		34	36 - 38		40 - 42		48
mm	inch	DN	40 to 50	65	80 to 90	100	125	150 - 200	250	300 - 350	400	450	500	550	600	650 - 700	750 - 800	850	900 - 950	1000 - 1100	1200	1220+							
50.8	2		1	1	1	1	1	1	1	1	1	1	1	1	1	1	1	1	1	1	1	1	1	1	1	1	1	4	
63.5	2.5		1	1	1	1	1	1	1	1	1	1	1	1	1	1	1	1	1	1	1	1	1	1	1	1	2	4	
76.2	3		1	1	1	1	1	1	1	1	1	1	1	1	1	1	1	1	1	1	1	1	1	1	2	2	4	4	
88.9	3.5		1	1	1	1	1	1	1	1	1	1	1	1	1	2	1	1	2	2	2	2	2	2	2	2	2	4	4
101.6	4		1	1	1	1	1	1	1	1	1	1	1	1	2	2	1	2	2	2	2	2	2	2	2	2	3	4	4
114.3	4.5		1	1	1	1	1	1	1	1	1	1	2	2	2	2	2	2	2	2	2	2	2	2	2	3	3	4	4
127	5		1	1	1	1	1	1	1	1	1	2	2	2	2	2	2	2	2	2	2	2	2	3	3	3	3	4	4
139.7	5.5		1	1	1	1	1	1	1	2	2	2	2	2	3	2	2	3	3	3	3	3	3	3	3	3	3	4	4
152.4	6		1	1	1	1	1	1	2	2	2	2	2	2	3	3	3	3	3	3	3	3	3	3	3	3	3	4	4
165.1	6.5		1	1	1	1	2	2	2	2	2	3	3	3	3	3	3	3	3	3	3	3	3	3	3	3	3	4	4
177.8	7		1	2	2	2	2	2	2	2	3	3	3	3	3	3	3	3	3	3	3	3	3	3	3	3	3	4	4
190.5	7.5		2	2	2	2	2	2	2	3	3	3	3	3	3	3	3	3	3	3	3	3	3	3	3	3	3	4	4
228.6	9		2	3	3	3	3	3	3	3	3	3	3	3	3	3	3	3	3	3	3	3	3	3	3	3	3	4	4
241.3	9.5		3	3	3	3	3	3	3	3	3	3	3	3	3	3	3	3	3	3	3	3	3	3	3	3	3	4	4
254	10		3	3	3	3	3	3	3	3	3	3	3	3	3	3	3	3	3	3	3	3	3	3	3	3	4	4	4
266.7	10.5		3	3	3	3	3	3	3	3	3	3	3	3	3	3	3	3	3	3	3	3	3	3	3	3	4	4	4
279.4	11		3	3	3	3	3	3	3	3	3	3	3	3	3	4	3	3	3	4	4	4	4	4	4	4	4	4	4
292.1	11.5		3	3	3	3	3	3	3	3	3	3	3	3	4	4	3	4	4	4	4	4	4	4	4	4	4	4	4
304.8	12		3	3	3	3	3	3	3	3	3	3	3	4	4	4	4	4	4	4	4	4	4	4	4	4	4	4	4
317.5	12.5		3	3	3	3	3	3	3	3	4	4	4	4	4	4	4	4	4	4	4	4	4	4	4	4	4	4	4
330.2	13		3	3	3	3	3	3	3	4	4	4	4	4	4	4	4	4	4	4	4	4	4	4	4	4	4	4	4
342.9	13.5		3	3	3	3	3	4	4	4	4	4	4	4	4	4	4	4	4	4	4	4	4	4	4	4	4	4	4
355.6	14		3	3	3	3	4	4	4	4	4	4	4	4	4	4	4	4	4	4	4	4	4	4	4	4	4	4	4
368.3	14.5		3	3	4	4	4	4	4	4	4	4	4	4	4	4	4	4	4	4	4	4	4	4	4	4	4	4	4
381	15		4	4	4	4	4	4	4	4	4	4	4	4	4	4	4	4	4	4	4	4	4	4	4	4	4	4	4

Step 3: Refer to Ordering Information to select corresponding part numbers

Fig. 1 Standard installation with "A" dimension using a weldolet (threadolet)

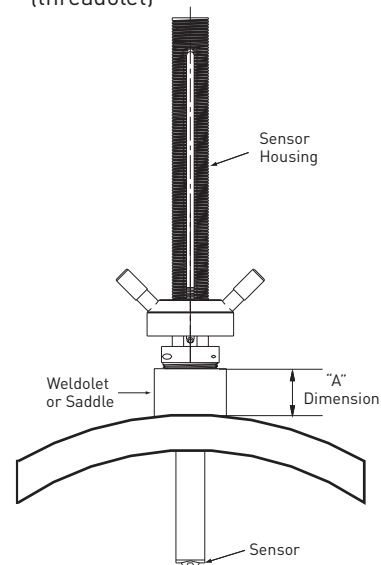
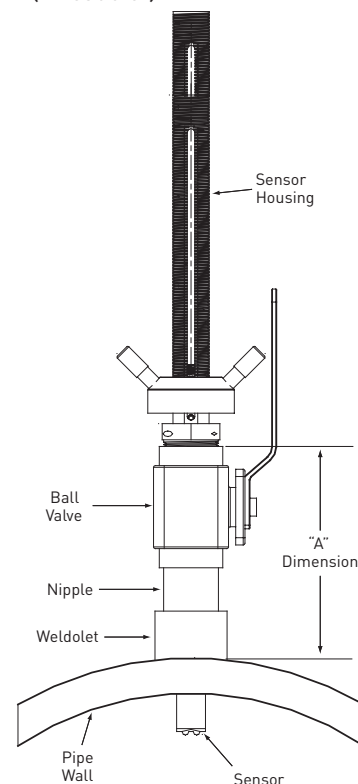

Fig. 2 Hot-Tap installation with "A" dimension using a ball valve, short nipple and weldolet (threadolet)



Legend:

- Use 03-2552-1, max. protrusion = 185 mm (7.3 in.)
- Use 3-2552-2, max. protrusion = 236 mm (9.3 in.)
- Contact your local GF sales office for information
- Contact your local GF sales office for more information.

Ordering Information

Model 2552 Metal Magmeter Ordering Matrix				
3-2552	Mounting Depth Options - Choose One*			
	-1	Sensor protrusion depth = 7.3 inches*		
	-2	Sensor protrusion depth = 9.3 inches*		
	Process Connection Options - Choose One			
	1	1 1/4 inch NPT Process Connection Threads**		
	2	1 1/4 inch ISO Process Connection Threads**		
	Cable and Connector Options - Choose One			
	-A	Fixed Cable, 7.6m (25 ft); no connector		
	-B	Watertight sensor connector; cable sold separately		
	Output options - Choose One			
	-11	Frequency or Digital (S ³ L); for use with any Signet Flow Instrument or the 8900 Multi-Parameter Controller		
	-12	4 to 20 mA output		
3-2552	-1	-1	-A	-12
Example Part Number				

* Customer must determine stack height (ball valve, nipple, weldolet, etc.). Refer to Sensor Selection on previous page to determine "A" dimension.

** 1.25 inch process connection is the standard thread size: 1.5 or 2 inch adapters are listed under Accessories.

Model 2552 Ordering Notes:

- 1) Sensor protrusion depth is the distance from the bottom of the sensor housing to the tip of the sensor.
- 2) For new Hot-Tap installations, a 1.25 inch ball valve is recommended.
- 3) See Sensor Selection Guide on previous page to determine the sensor length required.

Application Tips:

- Minimum process liquid conductivity requirement is 20µS/cm.
- 1.5 inch and 2 inch retrofit adapters are available for replacement installations of Signet 2550 and 2540 sensors.

Mfr. Part No.	Code	Mfr. Part No.	Code
3-2552-11-A-11	159 001 505	3-2552-21-A-11	159 001 513
3-2552-11-A-12	159 001 506	3-2552-21-A-12	159 001 514
3-2552-11-B-11	159 001 507	3-2552-21-B-11	159 001 515
3-2552-11-B-12	159 001 508	3-2552-21-B-12	159 001 516
3-2552-12-A-11	159 001 509	3-2552-22-A-11	159 001 517
3-2552-12-A-12	159 001 510	3-2552-22-A-12	159 001 518
3-2552-12-B-11	159 001 511	3-2552-22-B-11	159 001 519
3-2552-12-B-12	159 001 512	3-2552-22-B-12	159 001 520

Accessories and Replacement Parts

Mfr. Part No.	Code	Description
2120-1512	159 001 425	1.5 x 1.25 inch NPT adapter for retrofitting 2540 installation to 2552 - 316 stainless steel
2120-2012	159 001 426	2 x 1.25 inch NPT adapter for retrofitting 2550 installation to 2552 - 316 stainless steel
3-2552.392	159 001 530	1.25 in. NPT full port stainless steel ball valve and nipple kit
3-2552.393	159 001 531	1.25 in. NPT full port brass ball valve & nipple kit
3-2552.394	159 001 532	1.5 in. NPT conduit adapter, aluminum
4301-2125	159 001 533	1.25 in. NPT full port ball valve - brass
4301-3125	159 001 387	1.25 in. NPT full port ball valve - stainless steel
3-0232	159 000 865	RS232 set-up tool (PC compatible)
5541-4184	159 001 388	4-conductor, 22 AWG, water-tight connector, 4m (13 ft)
5541-4186	159 001 389	4-conductor, 22 AWG, water-tight connector, 6m (19.5 ft)
special order	special order	4-conductor, 22 AWG, water-tight connector, customer specified length