

Signet 2760 DryLoc™ pH/ORP Preamplifier

English



3-2760.090

Rev. C 9/05

English

WARNING!



SAFETY INSTRUCTIONS

1. Depressurize and vent system prior to installation or removal.
2. Confirm chemical compatibility before use.
3. Do not exceed maximum temperature/pressure specifications.
4. Wear safety goggles or faceshield during installation/service.
5. Do not alter product construction.
6. When using chemicals or solvents care should be taken and appropriate eye, face, hand, body, and/or respiratory protection should be used.

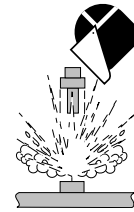

Description

The Signet 2760 pH/ORP Preamplifiers with DryLoc™ connectors are part of Signet's growing line of sensors for industrial fluid measurement and control.

There are two styles of Preamplifiers, and each is available with NPT or ISO threads at the cable outlet. They all connect to three different families of pH and ORP electrodes to supply an amplified mV (analog) signal to Signet instruments.

The 2760 family also offers a set of connectors to link the same electrodes to third-party equipment that require a direct millivolt signal for pH measurement without amplification.

Technical Data

General

Compatible Electrodes:

Signet DryLoc Electrodes: 2754-2774, 2764-2767, 2774-2777

Compatible Instruments:

Preamplifier models: Signet 5700, 8750

Connector models: non-Signet products

Response Time (includes response time of electrodes):

- pH: <6 s for 95% of change
- ORP: application dependent
- Temperature, τ : 20 s

Electrical (2760-1, -2, -11, -21 Preamplifiers)

- Maximum Offset: ± 7 mV
- Input Impedance, Z: $>10^{11}\Omega$
- Supply Voltage (V+ to V-): 6 to 12 VDC
- Current consumption: <1 mA

Environmental

- Enclosure Rating: 2760-1, -2, -3, -4: NEMA 6P/IP68
2760-11, -21, -31, -41: NEMA 4
with electrode and watertight conduit
and/or extension pipe connected

Materials:

- Submersible versions: CPVC (Gray)
- In-Line versions: PBT (Yellow)

Cable: 4.6m (15 ft.) 6-cond w/shield, 22AWG

Maximum cable: 122 m (400 ft.)

Shipping Weight: 0.64 kg (1.41 lb)

Operating Temperature: 0°C to 85°C (32°F to 185°F)

Storage Temperature: -20°C to 85°C (-4°F to 185°F)

Relative Humidity: 0 to 95%, non-condensing
(without electrode connected)

Standards and Approvals

- CE
- Manufactured under ISO 9001:2000 for Quality and ISO 14001:1996 for Environmental Management

Dimensions

3-2760-1 Preamplifier, Submersible, NPT

3-2760-2 Preamplifier, Submersible, ISO

3-2760-3 Connector, Submersible, NPT

3-2760-4 Connector, Submersible, ISO

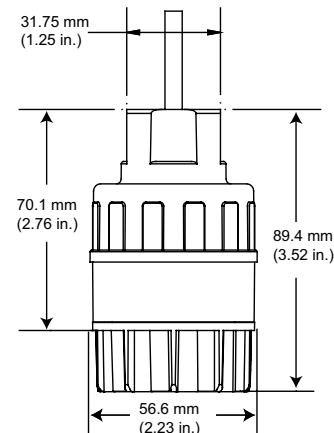

3-2760-11 Preamplifier, In-line, NPT

3-2760-21 Preamplifier, In-line, ISO

3-2760-31 Connector, In-line, NPT

3-2760-41 Connector, In-line, ISO

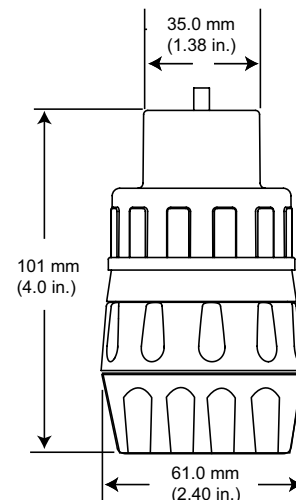

In-line Assembly and Installation

2760 In-Line models used with 2754-2757 series electrodes:

- 2754-2757 require a Signet flow installation fitting.
2754-2757 electrodes are sealed by the O-ring when it is installed into the installation fitting.
- The lower threaded nut is required to attach the electrode to the installation fitting. **HAND-TIGHTEN** the threaded nut onto the installation fitting. **DO NOT USE TOOLS!**
- Seat the 2760 DryLoc connector onto the top of the electrode. Open the DryLoc connector by turning the upper locking ring $\frac{1}{4}$ -turn clockwise.
- Turn the locking ring $\frac{1}{4}$ -turn counter-clockwise to lock the preamplifier in place. The mechanism will "click" when it is locked.
When fully assembled the 2760 will stand about 100 mm (4 in.) above the installation fitting.

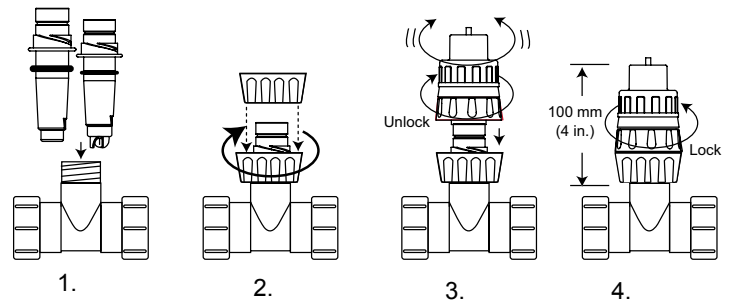

2760 In-Line models used with 2764-2767 or 2774-2777 series electrodes:

- 2764-2767: Install a 1 in. NPT pipe tee into the process line.
2774-2777: Install a $\frac{3}{4}$ in. NPT pipe tee into the process line.
Wrap the process threads on the electrode with an appropriate sealant (example: Teflon tape) to create a water-tight connection. **HAND-TIGHTEN** the electrode into the installation fitting. **DO NOT USE TOOLS!**

- The lower threaded nut may be dropped onto the top of the electrode if , or it may be discarded. It is not necessary for these electrodes.
- Seat the 2760 DryLoc connector onto the top of the electrode. Open the DryLoc connector by turning the upper locking ring $\frac{1}{4}$ -turn clockwise.
- Turn the locking ring $\frac{1}{4}$ -turn counter-clockwise to lock the preamplifier in place. The mechanism will "click" when it is locked.
When the 2760 Preamplifier is fully assembled with one of the threaded electrodes (276X and 277X models) it will stand approximately 18 cm (7 in.) from the process threads to the top of the preamplifier.

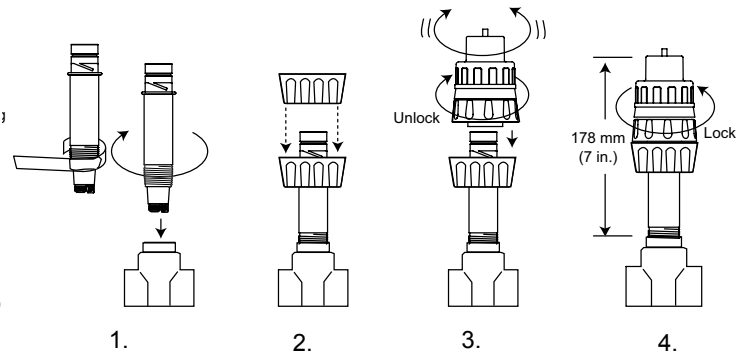

2760 Submersible models used as in-line system:

The Submersible 2760 design can also be used in-line when using the 2764-2767 series or the 2774-2777 series electrodes.

- 2764-2767: Install a 1 in. NPT pipe tee in the process line.
2774-2777: Install a $\frac{3}{4}$ in. NPT pipe tee in the process line.
Wrap the process threads on the electrode with an appropriate sealant (example: Teflon tape) to create a water-tight connection.
Remove the threaded nut from the preamplifier and place it around the electrode from the bottom as illustrated.
- HAND-TIGHTEN** the electrode into the installation fitting. **DO NOT USE TOOLS!**
- Seat the 2760 DryLoc connector onto the top of the electrode.
- Lift the threaded nut up and thread it hand-tight onto the preamplifier.
- When the 2760 Preamplifier is fully assembled with one of the threaded electrodes (276X and 277X models) it will stand approximately 18 cm (7 in.) from the process threads to the top of the preamplifier.

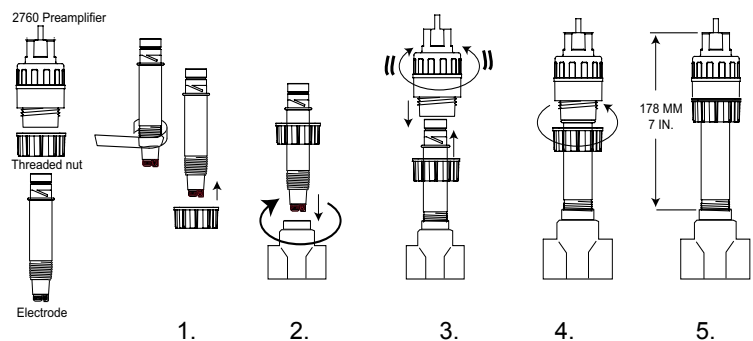

- The 2760 Preamplifier signal can be routed to a Signet 5700 ProPoint pH Monitor, or to any model of the 3-8750 pH Transmitter.
- If the preamplifier cable must be extended beyond the standard 15 ft. that is supplied with the 2760, use a junction box to terminate the wires.

Note: Do not extend the 2760 cable more than 120 m (400 ft.).

Wet-tap Assembly and Installation

The 2760 DryLoc Preamplicifier can be used to connect Signet 3719 Wet-tap electrodes to a pH or ORP instrument.

1. **Select the process fitting**
 - Select a low profile installation saddle with a 1½ in. or 2 in. outlet.
 - The 3719 is available with NPT or ISO thread options.
 - The 3719 can also be adapted to fit into tee fittings. Refer to the 3719 pH Wet-tap instructions for detailed information.
2. **Install the wet-tap and the electrode**
 - Install the 3719 into the fitting, then insert the electrode into the assembly.
3. **Attach the preamplifier to the electrode**
 - Attach the 3-2760-11 or -21 Preamplifier to the bayonet fitting at the top of the electrode.
4. **Connect the 2760 Preamplifier to the instrument**
 - The 2760 Preamplifier signal can be routed to any compatible pH instrument. Wet-tap electrodes are available with a PT1000 temperature compensation device or with a 3K Balco temperature compensation device.

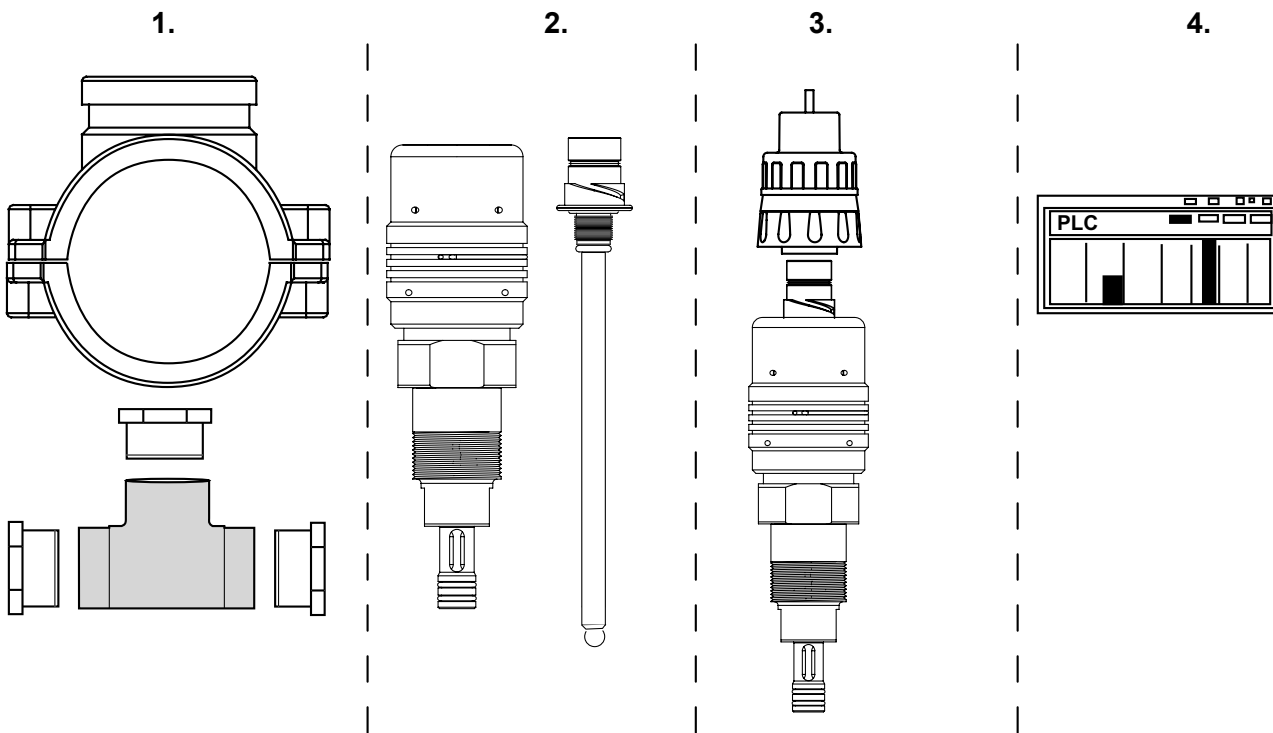

2760 Submersible Sensor Assembly and Installation

The submersible 2760 can be installed in a tank or vessel if conditions are within pressure and temperature specifications. The 2760 is able to withstand fluid temperatures up to 85°C, but the electrode tolerances vary. Check the specifications of each component before installation.

1. Insert any DryLoc electrode into base of the 2760 and turn until keyed contacts are seated.
2. Thread retaining cap over electrode and hand-tighten onto 2760.
 - A light coat of a non-petroleum based lubricant on the sensor O-ring will ease the installation.
 - Keep the DryLoc electrical interconnection between electrode and preamplifier dry and clean at all times.
3. Attach 3/4 in. watertight pipe to the top of the 2760. Secure the threaded connection to prevent any leakage.
 - For additional defense against possible accumulation of condensation at the back seal area of the 2760, fill the lower 3 to 4 inches (75-100 mm) of conduit or extension pipe with a flexible sealant such as silicone.

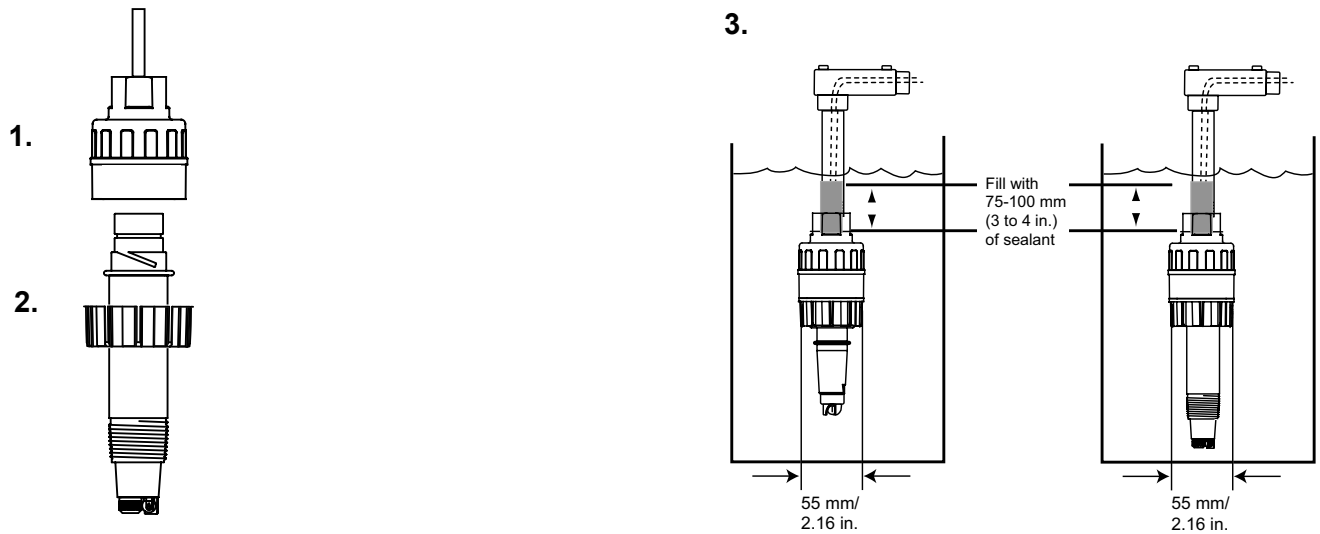

Use standard installation hardware to connect the submersible 2760 directly to external equipment.

OR

The 8052-1 NPT Mount Junction box connects to 3/4 in. pipe or conduit and provides convenient wiring termination.

OR

The 8050-1 Universal Mount junction box mounts flat onto a wall or can be strapped to a post or pipe.

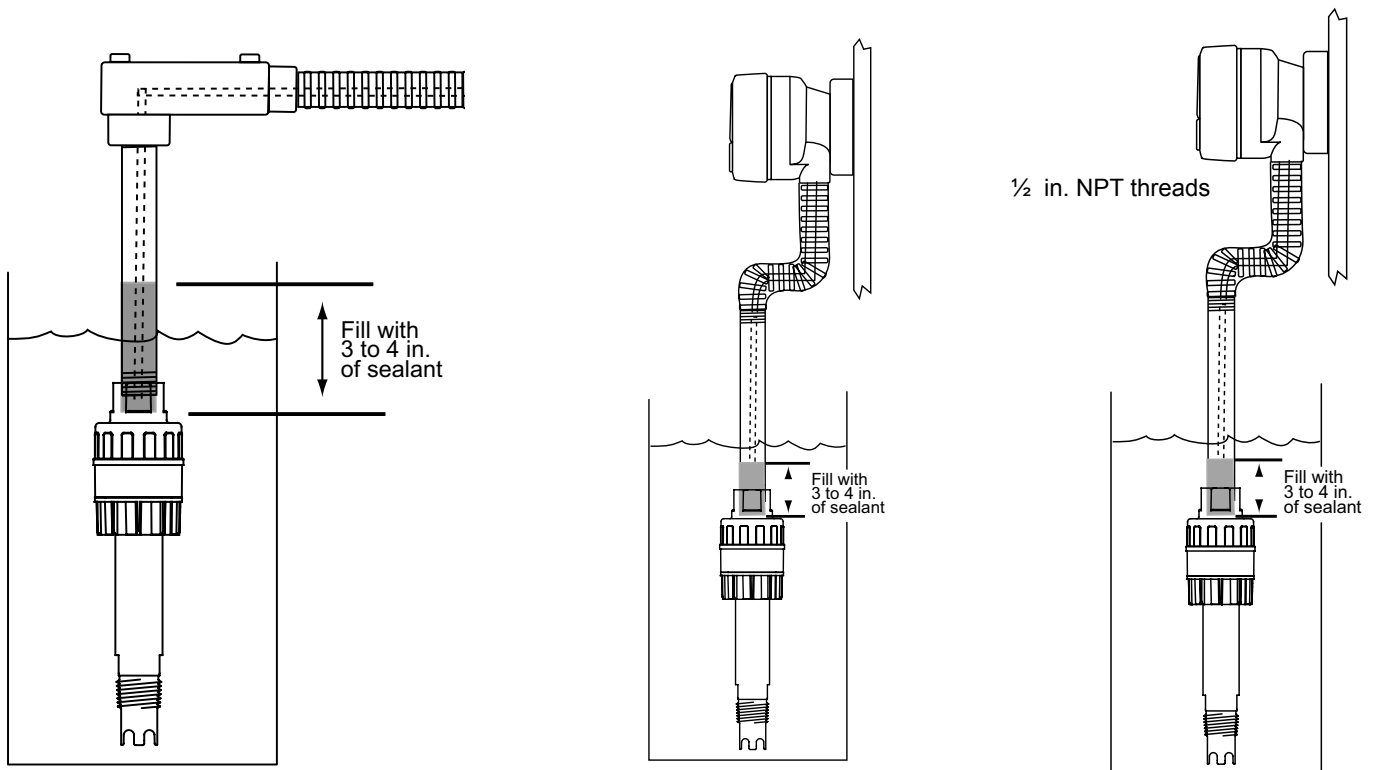

Wiring to Signet Instruments

Any of these electrodes can be connected to the Signet ProPoint and ProcessPro pH instruments using the 3-2760-1(X) or -2(X) Preamplifiers.

Wiring diagrams illustrate the actual terminals on these products for convenience.

**Signet 8750-X
ProcessPro pH/ORP Transmitter**



**Signet 5700
ProPoint pH/ORP Monitor**

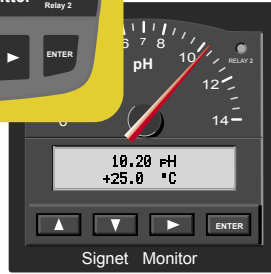

Standard output,
Signet installation fittings
3-2754-1
3-2754-HF-1
3-2756-DI-1
3-2756-WT-1
3-2756-WTP-1

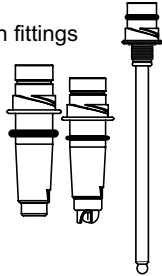

Standard output,
3/4 in. Process conn.
3-2774
3-2775
3-2776
3-2777



Differential output,
1 in. Process conn.
3-2764-1
3-2765-1
3-2766-1
3-2767-1



3-5700 pH/ORP Monitor

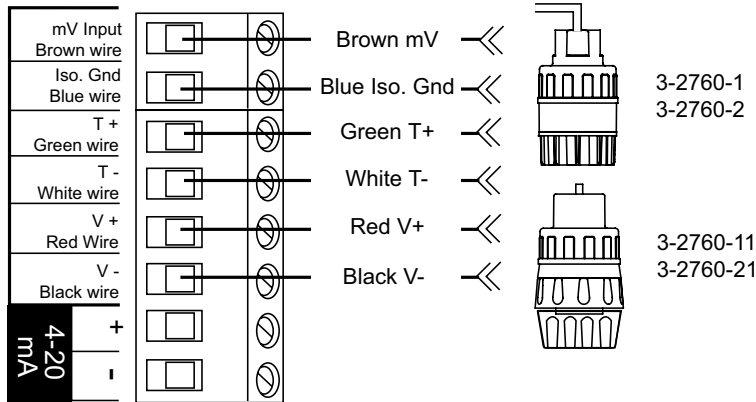

ProcessPro pH/ORP Transmitter

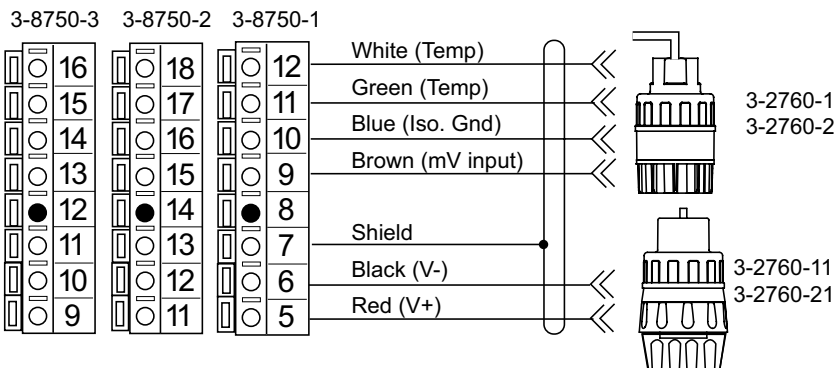

Connect this terminal ● to Earth GND to reduce electrical interference.

Wiring from 2760 DryLoc Preamplifier to Other Manufacturer's Equipment

The 2760-1/-2 Preamplifier and electrode options may be used with third party equipment if the equipment can process the AMPLIFIED mV signal for pH and is compatible with one of the temperature compensation options. (3KΩ, PT1000, or 300Ω).

Refer to the manufacturer's manual for wiring details. Other products may use different terms to identify the function of each conductor.

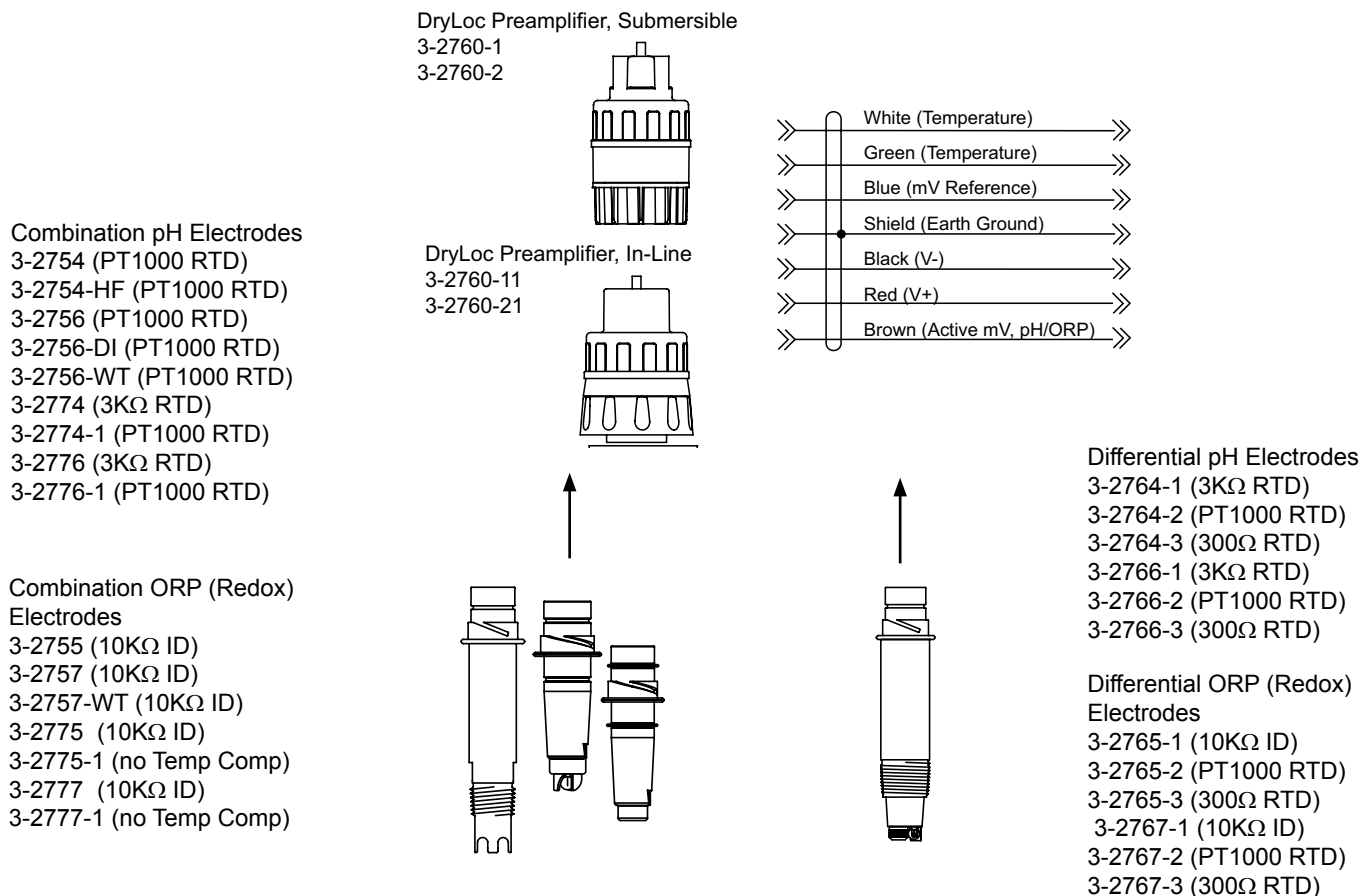

Wiring from 2760 DryLoc Connectors to Other Manufacturer's Equipment

The 2760-3/4 Connectors can be used to interface other manufacturer's instruments to these Signet DryLoc pH and ORP electrodes. The instrument must be able to process a UNAMPLIFIED mV signal from the pH or ORP electrode. Several different temperature devices are available.

Refer to the manufacturer's manual for wiring details. Other products may use different terms to identify the function of each conductor.

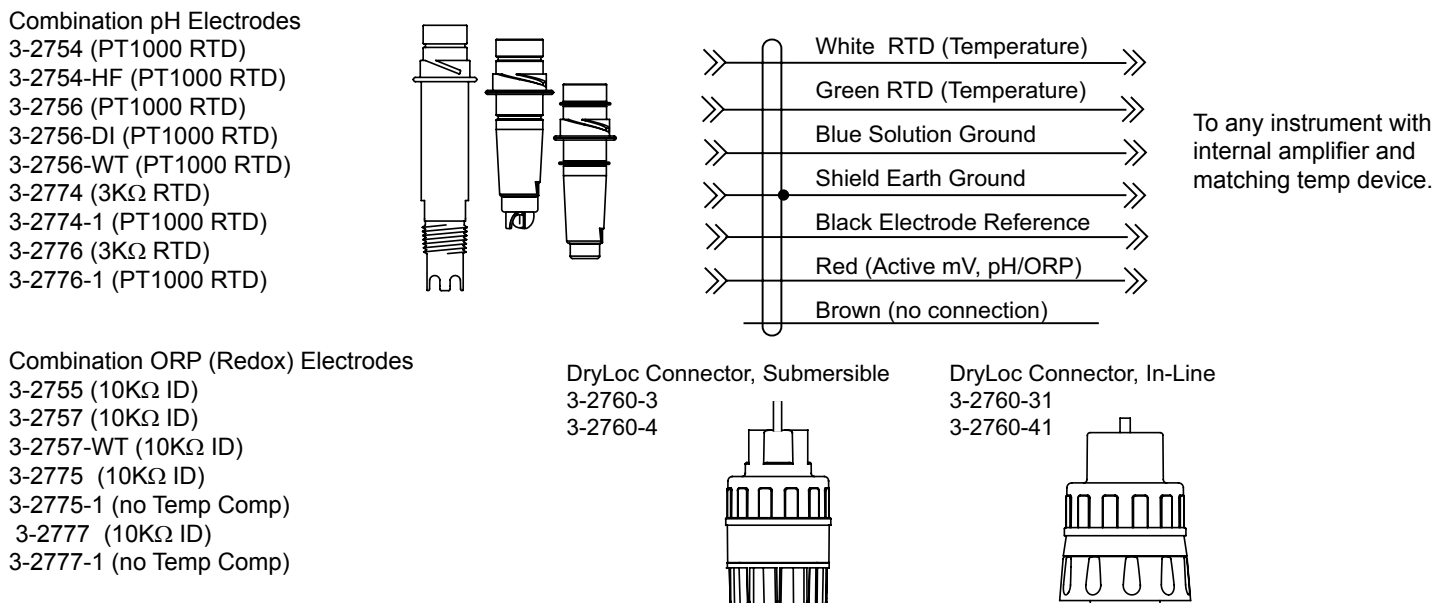

Notes

Ordering Information

Mfr. Part No.	Code	Description
3-2760-1	159 000 939	Submersible Preamplifier with 3/4 in. NPT threads and 4.6 m (15 ft.) cable
3-2760-2	159 000 940	Submersible Preamplifier with 3/4 in. ISO threads and 4.6 m (15 ft.) cable
3-2760-3	159 000 941	Submersible Connector with 4.6 m (15 ft.) cable and 3/4 in. NPT threads
3-2760-4	159 000 942	Submersible Connector with 4.6 m (15 ft.) cable and ISO 7/1R 3/4 in. threads
3-2760-11	159 001 367	In-line Preamplifier with 3/4 in. NPT threads and 4.6 m (15 ft.) cable
3-2760-21	159 001 368	In-line Preamplifier with 3/4 in. ISO threads and 4.6 m (15 ft.) cable
3-2760-31	159 001 369	In-line Connector with 4.6 m (15 ft.) cable and 3/4 in. NPT threads
3-2760-41	159 001 370	In-line Connector with 4.6 m (15 ft.) cable and ISO 7/1R 3/4 threads

Accessories and Replacement Parts

Calibration Tools

3-2759	159 000 762	pH/ORP System Tester (adapter cable sold separately)
3-2759.391	159 000 764	2759 Adapter Cable for use w/2760 DryLoc Preamplifier
3-0700.390	198 864 403	pH Buffer Kit (1 each 4, 7, 10 pH buffer in powder form, makes 50 mL)
5523-0624	159 000 636	Cable, 6 conductor, 24 AWG shielded

Electrodes

DryLoc pH Electrodes

3-2754-1	159 001 380	Combo flat pH Electrode, 3KΩ RTD, Signet installation fittings
3-2754-HF-1	159 001 381	Combo flat pH Electrode, 3KΩ RTD, for use in HF, Signet installation fittings
3-2756-DI-1	159 001 382	Combo bulb pH Electrode, 3KΩ RTD, for use in DI, Signet installation fittings
3-2756-WT-1	159 001 383	Combo bulb pH Electrode, 3KΩ RTD, for use in 3719 Wet-tap
3-2756-WTP-1	159 001 384	Combo plastic bulb pH Electrode, 3KΩ RTD, for use in 3719 Wet-tap

3-2764-1	159 000 943	Differential pH Electrode, 3KΩ RTD, 1 in. NPT process connection
3-2764-2	159 000 944	Differential pH Electrode, PT1000 RTD, 1 in. NPT process connection
3-2764-3	159 000 945	Differential pH Electrode, 300Ω RTD, 1 in. NPT process connection
3-2766-1	159 000 949	Differential pH Electrode, 3KΩ RTD, 1 in. NPT process connection
3-2766-2	159 000 950	Differential pH Electrode, PT1000 RTD, 1 in. NPT process connection
3-2766-3	159 000 951	Differential pH Electrode, 300Ω RTD, 1 in. NPT process connection

3-2774	159 000 955	Combo flat pH Electrode, 3KΩ RTD, 3/4 in. NPT process connection
3-2774-1	159 000 956	Combo flat pH Electrode, PT1000 RTD, 3/4 in. NPT process connection
3-2776	159 000 959	Combo flat pH Electrode, 3KΩ RTD, 3/4 in. NPT process connection
3-2776-1	159 000 960	Combo flat pH Electrode, PT1000 RTD, 3/4 in. NPT process connection

DryLoc ORP (Redox) Electrodes

3-2755	159 000 749	Combination flat ORP (Redox) Electrode, 10KΩ ID, Signet installation fittings
3-2757	159 000 752	Combination bulb ORP Electrode, 10 KΩ ID, Signet installation fittings
3-2757-WTP-1	159 001 385	Combo plastic bulb ORP Electrode, 10 KΩ ID, for use in 3719 Wet-tap
3-2765-1	159 000 946	Differential ORP (Redox) Electrode, 10KΩ ID, 1 in. NPT process connection
3-2765-2	159 000 947	Differential ORP (Redox) Electrode, PT1000 RTD, 1 in. NPT process connection
3-2765-3	159 000 948	Differential ORP (Redox) Electrode, 300Ω RTD, 1 in. NPT process connection
3-2767-1	159 000 952	Differential ORP (Redox) Electrode, 10KΩ ID, 1 in. NPT process connection
3-2767-2	159 000 953	Differential ORP (Redox) Electrode, PT1000 RTD, 1 in. NPT process connection
3-2767-3	159 000 954	Differential ORP (Redox) Electrode, 300Ω TC, 1 in. NPT process connection
3-2775	159 000 957	Combo flat ORP (Redox) Electrode, 10 KΩ ID, 3/4 in. NPT process connection
3-2775-1	159 000 958	Combo flat ORP (Redox) Electrode, no Temp, 3/4 in. NPT process connection
3-2777	159 000 961	Combo bulb ORP (Redox) Electrode, 10 KΩ ID, 3/4 in. NPT process connection
3-2777-1	159 000 962	Combo bulb ORP (Redox) Electrode, no Temp, 3/4 in. NPT process connection



George Fischer Signet Inc, 3401 Aerojet Avenue, El Monte, CA 91731-2882 U.S.A. • Tel. (626) 571-2770 • Fax (626) 573-2057
For Worldwide Sales and Service, visit our website: www.gfsignet.com • Or call (in the U.S.): (800) 854-4090

