

TOTAL CONTROL SYSTEMS

“The Standard of Measurement”

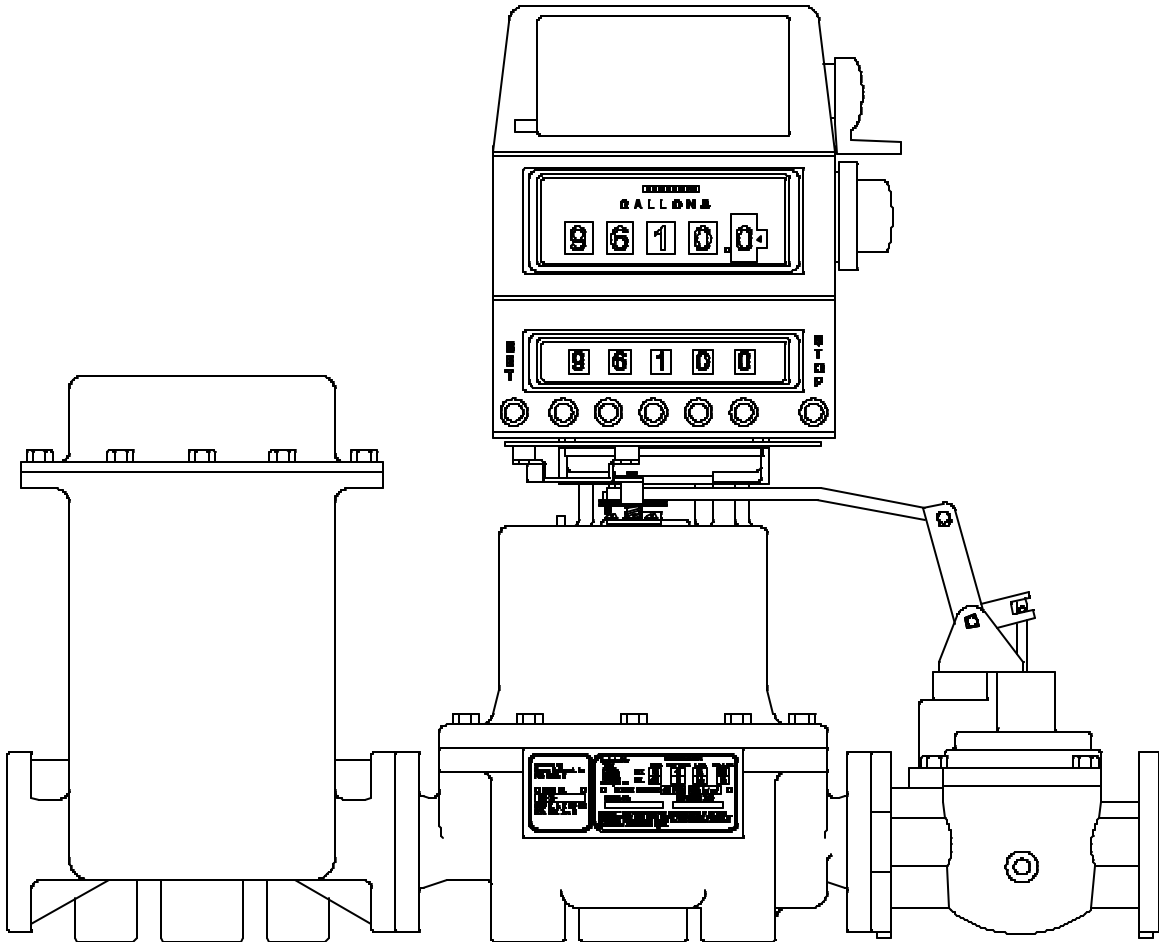

682-15 Piston Flow Meter SERVICE MANUAL

TOTAL CONTROL SYSTEMS
2515 Charleston Place • Fort Wayne, IN 46808
(800) 348-4753 • (260) 484-0382 • Fax (260) 484-9230
sales@tcsmeters.com • www.tcsmeters.com

SPECIFICATIONS

Type	Reciprocating 3 Piston Positive Displacement
Connections	1-1/2" companion flange
Flow Rate	Minimum: 0.2 GPM (0.76 LPM) Maximum: 40 GPM (151 LPM)
Working Pressure	150 PSI maximum (10.5 Bar)
Working Temperature	Model 682SP: -20°F to 200°F (-28.9°C to 93.3°C) Models 682AF & 682SS: -20°F to 400°F (-28.9°C to 204.4°C)
Units of Measure	1/10 th U.S. Gallons STANDARD; Litre's, Pounds, etc. available upon request.

FLOW METER TYPES

SP - Standard Petroleum	For metering refined petroleum products such as Leaded and Unleaded Gasoline, Fuel Oils, Diesel, Bio-Diesel, Kerosene, Aviation Gasoline, Vegetable Oils, Lubricating Oils, Ethylene Glycol (Anti-Freeze), etc.
AF - All Ferrous	For metering Pesticides, Nitrogen Solutions, Fertilizer, Solvents, Paints, Inks, Alcohols, Adhesives, Motor Oils, Molasses, Corn Syrup, Liquid Sugars, Deicing Fluids, etc.
SS - Stainless Steel	For metering all the same liquids as the SP and AF flow meters, however includes special handling fluids such as Nitric, Phosphorous and Glacial Acetic Acids, Anti-Icing Fluids, Vinegar, Fruit Juices and various other chemicals.

MATERIALS OF CONSTRUCTION

Type	Housing	Internals	Packing Seals	Piston Cups	Body Seals
SP	Cast Iron	Cast Iron & 316 SS	Viton® & Turcon®	Glass-filled TFE (Rulon)	Durlon® & Teflon®
AF	Cast Iron	Cast Iron & 316 SS	Simriz® & Turcon®	Glass-filled TFE (Rulon)	Durlon® & Teflon®
SS	316 SS	316 SS	Simriz® & Turcon®	Glass-filled TFE (Rulon)	Durlon® & Teflon®

® Viton is a registered trademark of E.I. DuPont de Nemours & Co.

® Simriz is a registered trademark of Freudenberg-NOK

® Teflon is a registered trademark of Dupont Dow Elastomers, L.L.C.

® Turcon is a registered trademark of Busak+Shamban.

® Durlon is a registered trademark of Gasket Resources, Inc.

682 METER OPERATION

The 682 meter is a true Positive Displacement Meter, with the inlet and outlet on the same horizontal plain (straight in - straight out). Within the meter, three plungers are fitted within their respective cylindrical measuring chambers. The plungers are joined to a wobble plate, which has a shaft extending from its upper surface. The wobble plate also has a valve pivot attached beneath it. The valve pivot drives a sliding valve from piston to piston as product flows, controlling the sequence of events.

The wobble plate shaft is always held at an inclined position by the center gear post, and the wobble plate itself is prevented from rotating by four guide pins on the pivot bracket assembly.

As product enters the meter, it initially flows into the upper housing. The sliding valve will now be in position to open one measuring cylinder. The plunger for that particular cylinder will be at the upper position. With the pressure below it relieved, and an upper housing full of product, the pressure on top of that plunger will cause it to move toward the bottom of the cylinder, thus forcing out the remaining product. As this occurs, another plunger will be forced from the down position to the upper position. The sliding valve moves via the wobble plate to open the inlet of this cylinder. As the plunger moves upward, it draws product into the measuring cylinder from the bottom. Once this plunger reaches the upper position, and the cycle will repeat, so long as product continues to enter the meter. If product flow stops, pressure in the meter equalizes and motion stops. Thus the meter only operates when product is flowing.

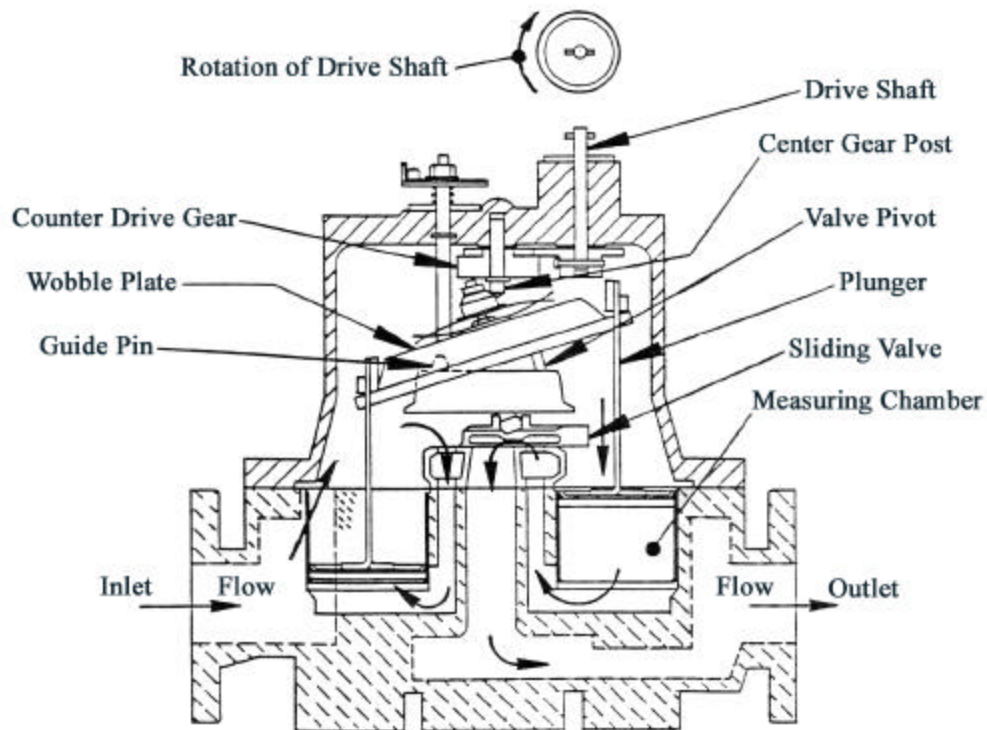

METER APPLICATION

When installing a meter into a system, several factors must be considered.

Flow Rate

The flow rate of the system must be within the meter's capability. The 682 meter can operate between 0.2 and 40 GPM. The flow rate of the system is dependent upon the system's pump capabilities, and the plumbing configuration, and the product to be measured.

Operating Pressure

The 682 meter can operate at pressures up to 150 PSI (10.5 BAR).

Compatibility

Products with suspended solids in them will scratch the piston liners and tear the plunger cups. The liquid to be metered must also be compatible with the meter. The standard petroleum (SP) is for service in petroleum with the meter. The all ferrous (AF) is for industrial and agricultural products, and the stainless steel (SS) is for service on products, which required 316 stainless steel for proper handling. Note that the 682 meter should not be used on water. Water has no lubricity and will drastically shorten the meter's service life. It is recommended that if the meter is to be used on water, it should be derated about 40 to 50 percent of flow.

Operating Temperature

The temperature range of the product to be metered must be within the meter's range. The SP meter can operate between -20°F and 200°F. The AF and SS meters can operate between 20°F and 400°F. Temperatures above 200°F require a heat extension.

Registration

The 682 meter normally uses a Veeder Root 5-wheel resetable register in 1/10th U.S. gallons, with an 8-digit non-resetable totalizer. Litre's, ounces, pounds or nearly any other unit of measure can be accommodated upon request.

Weights & Measures Approved Device

The TCS model 682 series flow meter holds the National Type Evaluation Program (NTEP) Certificate of Conformance meeting the National Institute of Standards and Technology (NIST) Handbook 44 requirements. The TCS model 682 series flow meter combines outstanding linear accuracy (+/-0.1% over entire 200:1 range) with superior performance. At constant flow, with all other conditions being constant, the flow meter does not vary more than +/- 0.01% in repeatability. The TCS model 682 series flow meter is virtually unaffected by changing viscosities. The inline meter design allows the TCS model 682 series flow meter to have a wide operating range (0.2 to 40 GPM) and fluid compatibility that has been proven over many years of service.

INSTALLATION AND START UP

Best Plumbing Configuration

Meters and piping should be installed to prevent drainage of product from the meter when the system is not running. One way to do this is to have the inlet and outlet of the meter lower than the associated system plumbing (sump position). Also, undue strain on the meter's 150# flanges from the connected piping must be avoided.

Slow Flooding Of System

When a pump is turned on and a valve opened in a new, dry system, tremendous pressure can be built up in the piping and forced through the meter. The high pressure and volume of air causes the meter to operate more quickly than normal. When product reaches the meter, there is an abrupt slowing of the meter plungers, which could cause damage to the register, plunger, gears or other components.

The recommended method of starting any system is to flood the piping gradually. This allows product to slowly force the air from the entire system.

Protection From Debris

On new installations, care must be taken to protect the meter from damage during start-up. Damage may result from the passage through the meter of welding slag or spatter, thread cuttings, rust, etc. There are several methods of protecting meters from this material including: the insertion of a spool (a flanged length of pipe equal in length to the meter and any accessories attached to the meter) in place of the meter until the system is flushed, temporarily bypassing the plumbing around the meter, or by installing a strainer ahead of the meter in the line.

Calibration

The meter's calibration must be checked (and adjusted, if necessary) using the product being metered by the user. Generally, calibrating it to a specific product and installation maximizes any meter's accuracy. The 682 meter exceeds the accuracy requirements specified in NIST Handbook 44, which is +/- 0.2% at the factory. In the field, NIST Handbook 44 maintenance test accuracy requirements are +/- 0.5% on a special test, and +/- 0.2% on a normal test. In a five gallon test, 0.2% = 2.31 cubic inches, 0.3% = 3.47 cubic inches, and 0.5% = 5.78 cubic inches.

STORAGE INSTRUCTIONS

Short periods of non-use of the meter (a week or less) will present no problem, provided that the meter remains full of product. For long periods of non-use, such as winter storage, the following procedure is recommended. Before long term storage, a good practice is calibration of the meter to determine that it is functioning properly.

- 1) To store the meter when it is left in line, flush the system with clean water until 40-50 gallons of water have gone through the meter.
- 2) Pump a 50% anti-freeze / 50% water solution through the entire system (100% RV antifreeze may be used instead). With the pump running, shut off a valve downstream from the meter, making sure that anti-freeze solution is present at that point. Then close an upstream valve, such that the meter remains full of anti-freeze solution.
- 3) Remove the register from the meter, and lubricate the drive coupling shaft. After lubrication it, replace the register onto the meter.
- 4) When starting the system after a period of storage, rechecking the meter's calibration as detailed earlier in the service manual.

CALIBRATION OF THE 682 METER

- A. It is important to test the repeatability and accuracy of your meter. To test repeatability:
- 1) Run a fast (high gallons per minute) test in your prover and record how much the meter is over or under registering. Do **NOT** change the meter's calibration.
 - 2) Run a slow (low gallons per minute) test and again record how much the meter is over or under registration.

If the results from the fast and the slow test are the same or close to the same, the meter can be successfully calibrated. If the test results differ beyond the rated tolerance of the meter, then repairs are necessary before the meter can be calibrated.

- B. A valve or nozzle must be at the end of the delivery hose (at the prover).
C. Turn on the pump and purge the system of air. Leave the pump on.
D. Shut off the valve at the end of the delivery hose and let the system pressurize.
E. Wet the prover and empty it, letting it drip for 30 seconds.
F. Reset the register on the meter to "0".
G. Fill the prover to the line marked "0".
H. Record what the register reads. Every 1/10 gallon difference between the register and the 5 gallons known to be in the prover equals a +/- 2% inaccuracy. For example, a reading of 4.9 gallons on the register, compared with a 5 gallon prover filled to the "0" line means the meter is giving away 2% of the product it meters.
I. The top disc on the calibrator has a tab sticking up. The tab is marked with a "plus" and a "minus" sign. This indicates "plus" product and "minus" product. By turning the disc in one direction or the other, product delivery will be increased or decreased.
J. A full revolution of the disc will change the calibration of the meter 3%. Therefore, if the meter shows 4.9 gallons on the register, the disc should be turned 2/3 of one revolution (2%) in the minus direction, since in this case we want less product through the meter (5 gallons passed through it in the test, and only registered 4.9 gallons).
K. Empty the prover and let it drip for 30 seconds.
L. Run a second test and make a fine adjustment; and then another test to check your fine adjustment.
M. Replace the pin into the disc, and seal it with the seal wire.

NOTE: If your meter has a mechanical or electronic preset, it should be set high enough so that it doesn't affect the calibration process. Only a valve at the prover should be used to control the flow during calibration.

KEY FEATURES OF 682 METER

TYPICAL ACCURACY CURVE 32 SSU SOLVENT

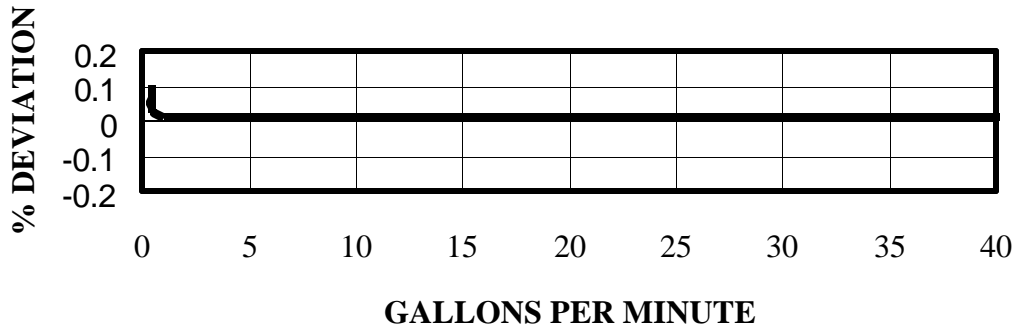

The 682 meter's linear accuracy (percent of error over or under the zero - error level) remains within design parameters ($\pm 0.2\%$) over its 0.2 to 40 GPM flow range. This exceeds the maintenance requirements for accurate custody transfer of product, as specified in the National Institute of Standards and Technology (NIST) Handbook 44.

PRESSURE DROP CURVE 32 SSU SOLVENT

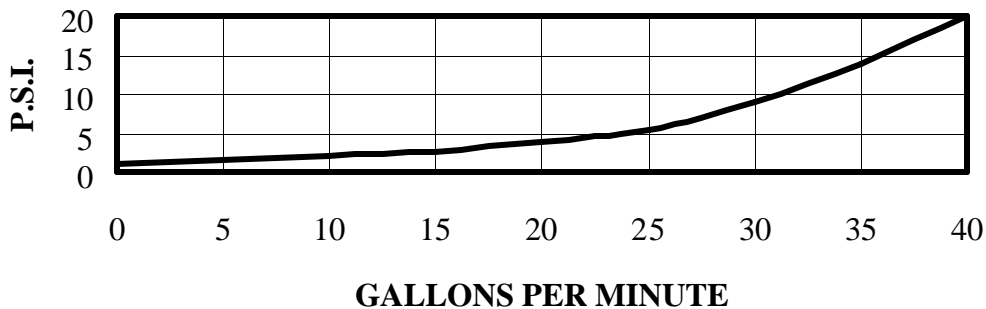

The 682 meter is mechanically capable of accurately metering products as slow as 0.2 GPM, and as quick as 40 GPM. Comparing the lowest and the highest flow rate results in a 200:1 turn down ratio for the 682 meter. The nameplate on the 682 meter states the flow rate as 2 - 40 GPM. This matches the flow range across which the meter was tested while earning a Certificate of Conformance from the National Type Evaluation Program (NTEP). It should be noted that as viscosity increases, maximum flow rate may decrease. See the viscous liquids performance graph for specific information. Viscosity is a measure of the flow ability of a product.

VISCOUS LIQUIDS PERFORMANCE

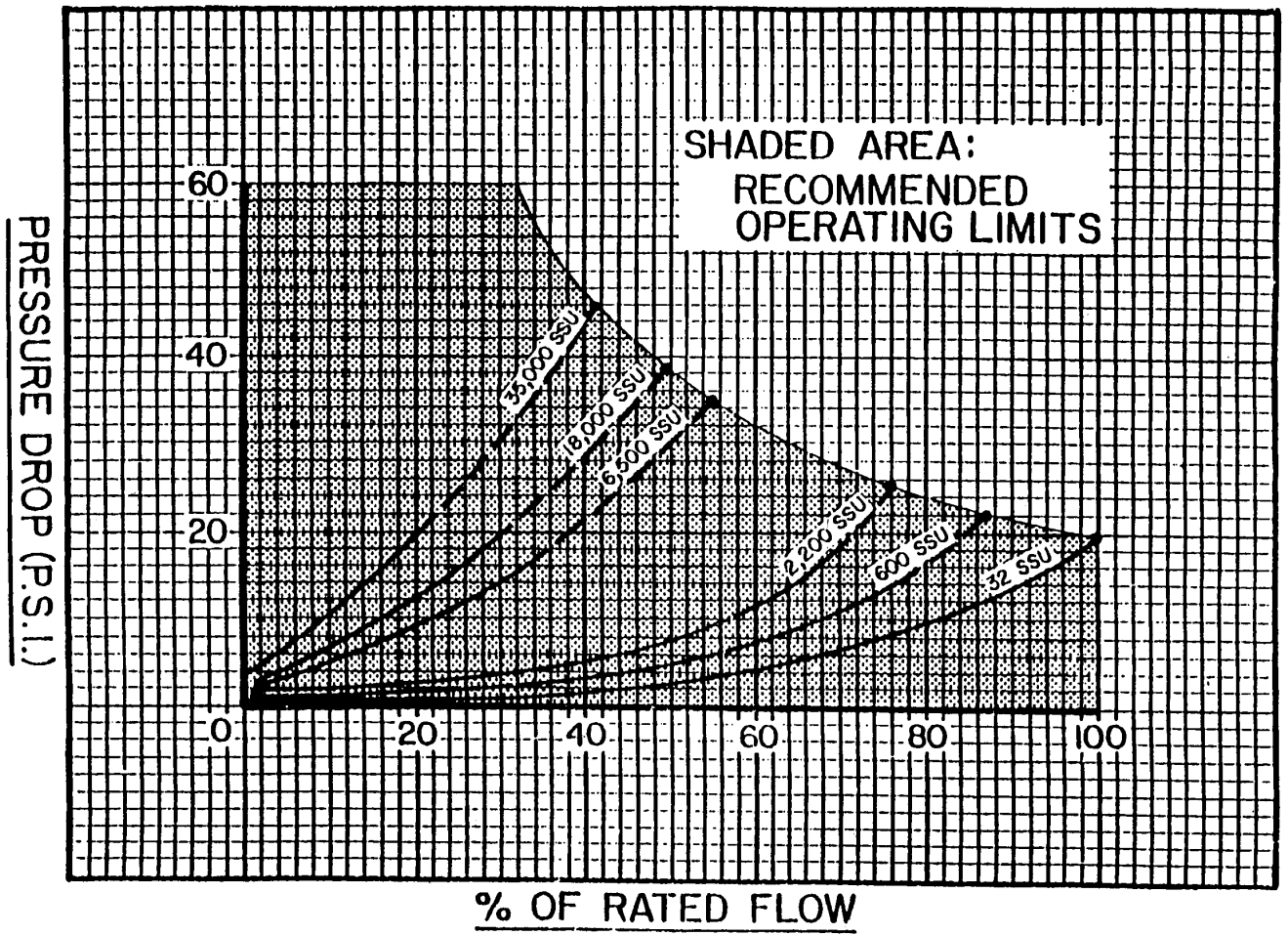

682 METER EXCHANGE PROGRAM

Overview

TCS offers an exchange program on the 682 AF and SP meters. The exchange price, equal to less than 1/3 the price of a new meter, after the credit given from the returned meter core. This makes the exchange program a powerful value - added option for 682 owners. Exchange meters are available for same day shipping. For the exchange program to continue smoothly, the used meter must be returned to TCS as promptly as possible, especially in the spring months.

Exchange Program Highlights

- 1) Exchange meters are always in stock.
- 2) Fast service to your customer minimizes downtime.
- 3) Customer needs fewer parts for inventory to ensure continuous operation.
- 4) All exchange meters maintain NTEP Certificate of Conformance.
- 5) The program applies to one meter or several meters at a time.
- 6) Meters are factory tested and calibrated.
- 7) Saves your customer money.
- 8) Repeat business for distributor.
- 9) Meter can be rebuilt numerous times.

Program Details

When a meter is exchanged, the user retains his register and adapter, as well as any other accessories he may have (presets, ticket printers, etc.). Separate exchange programs exist for registers and some other accessories.

The exchange meter, which is shipped from TCS, is calibrated and freshly painted. The exchange meter is guaranteed to be free of defects in material and workmanship for 180 days from the date it ships to the end user or distributor.

The used meter returned to TCS should be shipped freight prepaid (truck shipments are recommended for the safety of meter). ***It must be flushed and have a Material Safety Data Sheet (MSDS) identifying the product that was in the meter.*** Regardless of the condition of the internal parts of the meter, the only additional charge a distributor may be subject to is for the upper or lower housing. If the upper or lower housing is chipped, cracked, welded or similarly damaged and in need of replacement, then the dealer's core credit will be reduced accordingly.

DIMENSIONS

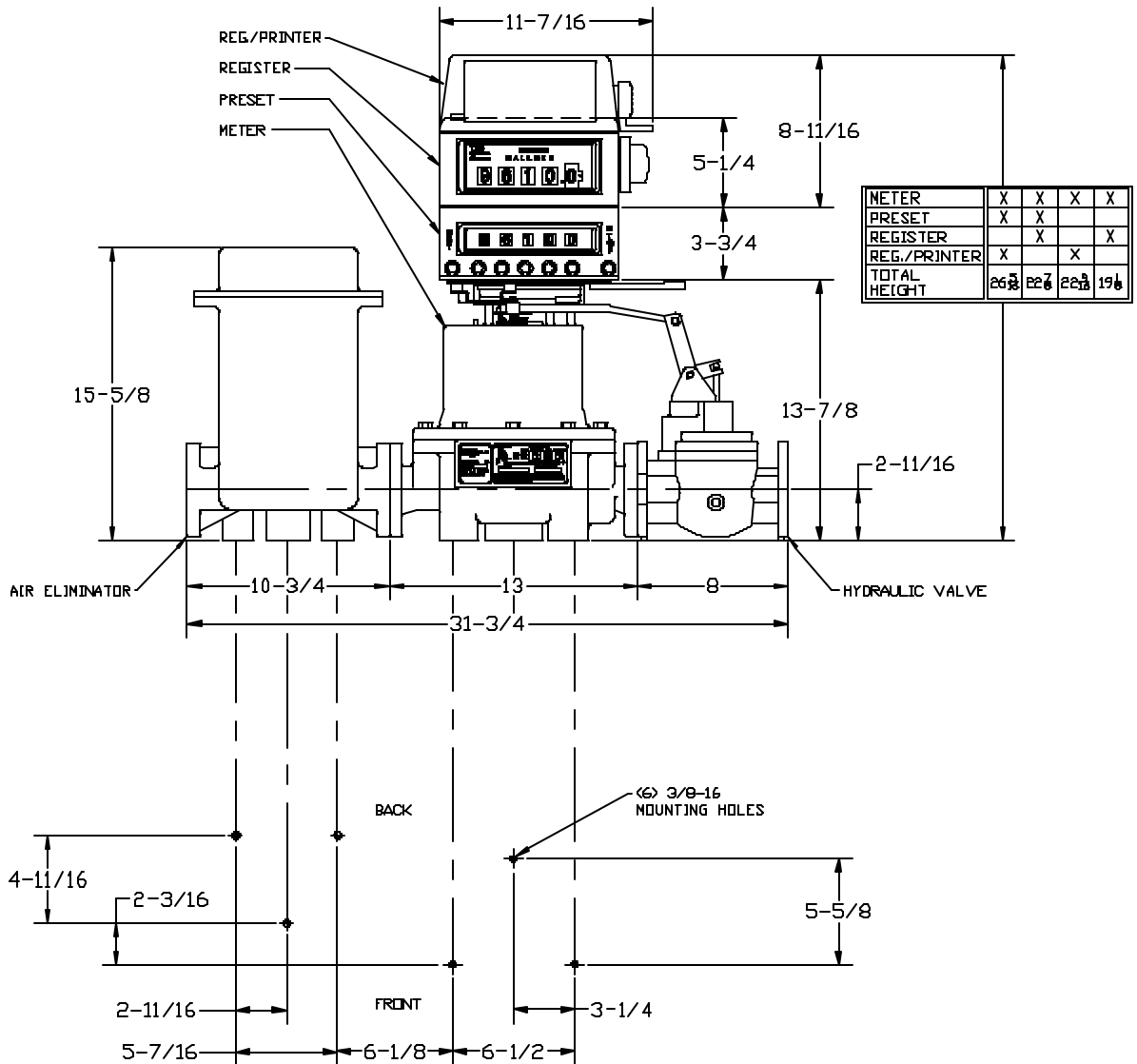
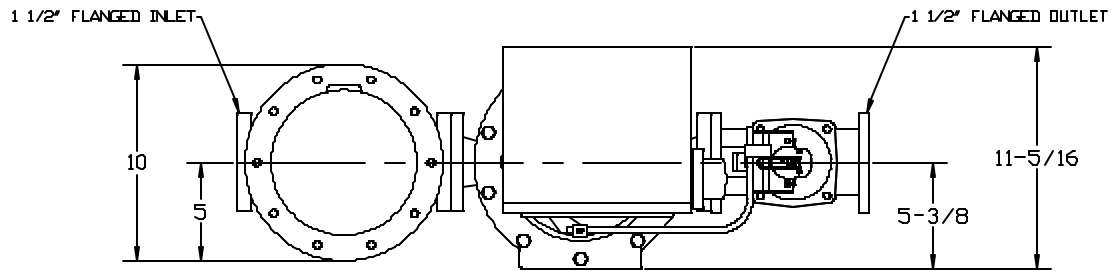

Measurements are in Inches.

TROUBLE SHOOTING THE 682 METER

The following is a list of common problems that can be encountered with a 682 meter, and possible causes and solutions for them.

- A. **PROBLEM:** The meter allows product to pass through it, but the register on the meter doesn't move.
- 1) Check the reset knob on the register. On older style Veeder Root registers, this knob can become stuck-in, which will disengage registration. In this case, though, the totalizer would still register.
 - 2) Check the screws that hold the gear plate onto the bottom of the register. If they become loose, neither the register nor the totalizer will register.
 - 3) The drive-gear coupling shaft (in the gear plate under the register) is broken or pin missing.
 - 4) The retaining ring on the counter drive gear has come off or broken, allowing the drive gear to disengage from the drive shaft gear assembly.
 - 5) The post on the wobble plate inside the meter has snapped off. When this happens, it usually indicates that air has been pumped through the meter.
 - 6) The connector on the piston assembly inside the meter is broken, allowing product to pass.
- B. **PROBLEM:** The meter will not deliver product and will not register.
- 1) Check any air eliminator and/or strainer screens in the system for blockage. Also, check all valves in the system for proper operation. If the problem still hasn't been discovered after those checks, determine what the pressure is before and after the meter (with the pump running). Equal readings would indicate the meter isn't necessarily the problem.
 - 2) On older style Tokheim 682 meters, there is a back pressure valve on the discharge of the meter, which can become stuck shut.
 - 3) If it is determined that the problem is in the meter itself, then the meter valve (inside the meter) is stuck down onto the valve body.
- C. **PROBLEM:** The meter delivers more product than what is registered.
- 1) First, the meter should be tested for repeatability. To test repeatability, run a fast (high gallons per minute) test in your prover and record how much the meter is under registering. Do **NOT** change the meter's calibration. Then, run a slow (low gallons per minute) test and again record the amount that the meter is under registering.
 - 2) If the results from the fast and the slow test are the same or close to the same, the meter has repeatability and can be calibrated. If the test results differ beyond the rated tolerance of the meter, then repairs are necessary.
NOTE: If the meter is more than 7% inaccurate (register reading of 4.65 or less gallons in a 5 gallon test), then it cannot be calibrated until repairs are made.
- D. **PROBLEM:** The meter delivers less product than what it registers.
- 1) The meter could have the wrong gear train in its register.
 - 2) Check for leaks on the suction side of the pump, including the pump seal. Air, which is sucked into the system and pushed through the meter would affect registration.
 - 3) After eliminating these possible causes, check the meter's repeatability, as outlined in problem C above.
 - 4) Register may need repair.
- E. **PROBLEM:** The meter has excessive knocking noise.
- 1) Check the calibrator on the meter. If it is adjusted too far out, excessive knocking is possible.
 - 2) If the problem isn't the calibrator, then the meter valve or another internal part may need repair or replacement.

METER ASSEMBLY

682-15

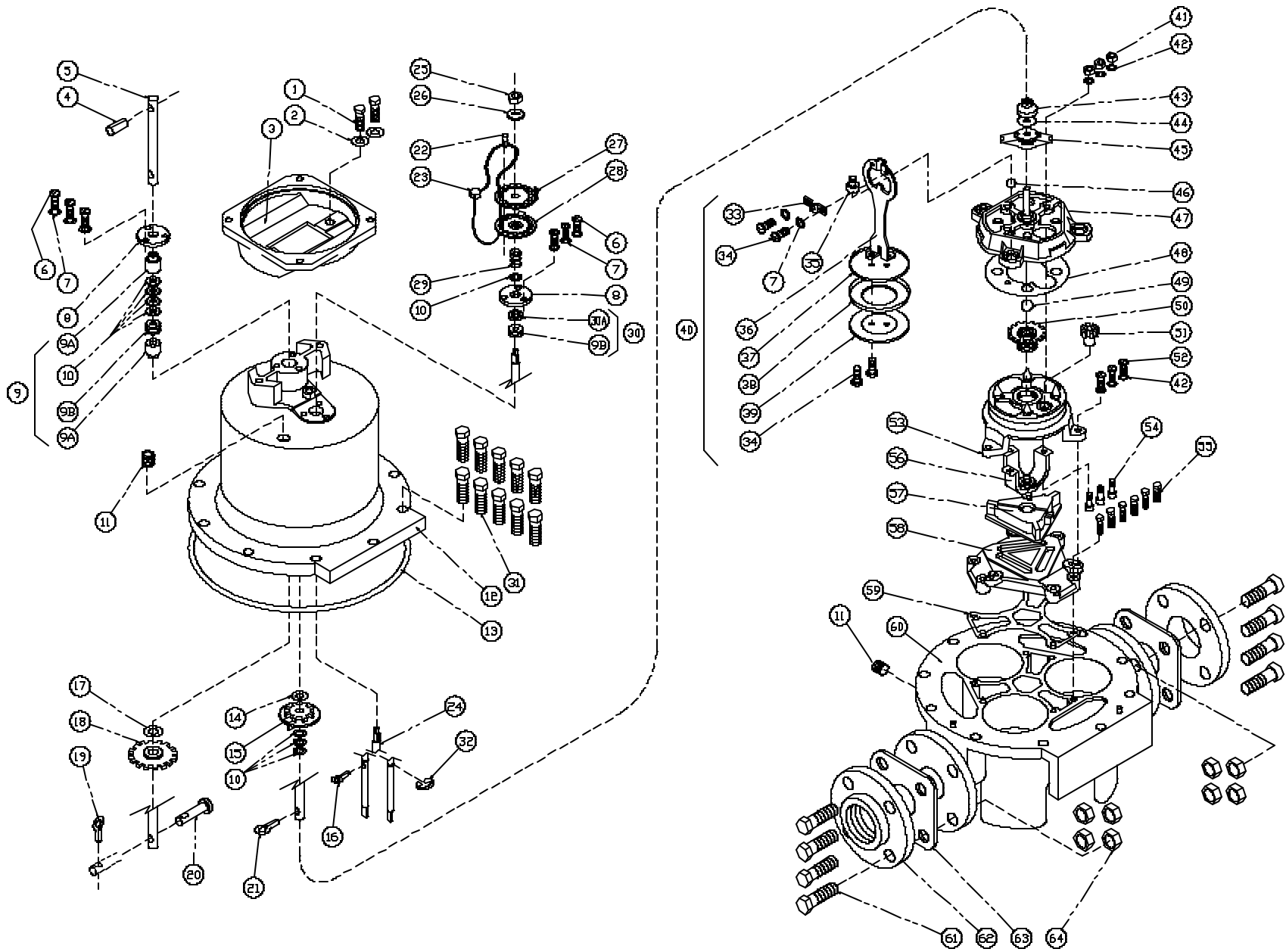

METER ASSEMBLY

682-15

ITEM#	MFG	DESCRIPTION	QTY	SP	AF	SS
1	TCS	Screw, 3/8-16 X 1-1/8	1	297-050361	297-050361	1-126333
2	TCS	Washer, 3/8 Split Lock	1	15-050641	15-050641	1-126334
3	TCS	Counter Support	1	1-312518	1-312518	1-312518
4	TCS	Roll Pin	1	49-052910	49-052910	3-130752
5	TCS	Drive Shaft	1	1-114815	1-114815	1-126900
6	TCS	Screw, 10-24 X 1/2	6	252-50001	252-50001	1-128279
7	TCS	Washer, #10 Split Lock	12	1-126316	1-126316	1-126316
8	TCS	Compression Washer	2	1-130872	1-130872	2-130872
9	TCS	Drive Shaft Packing Kit	1	226199-1	226199-1	226199-1
10	TCS	Washer, 9/16 OD X 0.10 T	10	1-125095	1-125095	1-126903
11	TCS	Pipe Plug, 1/4"	2	2-051913	2-051913	2-126146
12	TCS	Cover & Post Assembly	1	227006-1	227006-1	227006-3
13	TCS	Gasket, 8-3/16 ID Teflon	1	68-311105	1-315423	1-315423
14	TCS	Washer, 3/4 OD X 0.015 Rulon	1	1-125120	1-125120	1-125120
15	TCS	Counter Drive Gear Assembly	1	226136-1	226136-1	226136-2
16	TCS	Cotter Pin, 1/16 X 1/2	1	-	-	1-126318
17	TCS	Washer, 7/8 OD X 0.15 Rulon	1	1-125407	1-125407	1-125407
18	TCS	Drive Shaft Gear	1	226135-1	226135-1	226135-2
19	TCS	Cotter Pin, 3/16 X 1-1/4	1	13-052870	13-052870	1-126319
20	TCS	Drive Shaft Pin 1/4 X 1-3/32	1	1-126913	1-126913	1-126914
21	TCS	Cotter Pin, 1/16 X 1/2	1	1-126318	1-126318	1-126318
22	TCS	Seal Pin	1	1-019602	1-019602	1-126929
23	TCS	Seal Wire and Seal	1	1-118849	1-118849	1-118849
24	TCS	Compensator Shaft	1	1-224081	1-224081	1-224119
25	TCS	Nut, 5/16-18	1	2-050301	2-050301	1-126320
26	TCS	Compensating Washer	1	1-019797	1-019797	1-126927
27	TCS	Index Disc	1	1-126931	1-126931	1-126931
28	TCS	Index Plate	1	1-226085	1-226085	1-130853
29	TCS	Compression Spring	1	1-130935	1-130935	1-130935
30	TCS	Compensator Shaft Seal Kit	1	227000-1	227000-1	227000-1
31	TCS	Screw, 7/16-14 X 1-1/4	10	3-230958	3-230958	1-130879
32	TCS	Retaining Ring, 0.320 ID X 0.025 T	1	12-053420	12-053420	-
33	TCS	Bearing Retainer, Plunger	3	1-126957	1-126957	1-126957
34	TCS	Plunger Screw, 10-32 X 3/8	12	1-126329	1-126329	1-126329
35	TCS	Bearing Seat, Plunger	3	1-219378	1-219378	1-130908
36	TCS	Piston Connector, Plunger	3	1-126939	1-126939	1-126939
37	TCS	Plunger Disc	3	1-126878	1-126878	1-126878
38	TCS	Plunger Cup Kit (3 Cups)	1	218769-1	218769-1	218769-1
39	TCS	Plunger Cup Support	3	1-126876	1-126876	1-126876
40	TCS	Plunger Assembly	3	226182-2	226182-2	226182-2
41	TCS	Nut, 1/4-20	3	1-126321	1-126321	1-126321
42	TCS	Washer, 1/4 Split Lock	3	1-126317	1-126317	1-126317
43	TCS	Slack Roller Assembly	1	219800-1	219800-1	219800-2
44	TCS	Washer, 0.863 OD X 0.030 Rulon	1	1-125103	1-125103	-
45	TCS	Slack Spring Assembly	1	221403-2	221403-2	221403-5
46	TCS	Ball, 1/4 Dia.	3	1-124588	1-124588	2-130905
47	TCS	Wobble Plate Assembly	1	219331-1	219331-1	219901-2
48	TCS	Wear Plate	1	1-217934	1-217934	1-217934
49	TCS	Ball, 5/8 Dia.	1	1-125046	1-125046	1-130905
50	TCS	Main Pivot Assembly	1	219572-4	219572-4	219572-4
51	TCS	Compensating Pinion	1	1-129607	1-129607	2-129607
52	TCS	Screw, 1/4-20 X 3/4	3	1-126327	1-126327	1-126327
53	TCS	Main Pivot Bracket Assembly	1	218236-4	218236-4	219260-6
54	TCS	Slotted Screw, 1/4-20 X 1	3	1-126962	1-126962	1-126962
55	TCS	Screw, 1/4-20 X 1	6	1-126326	1-126326	1-126326
56	TCS	Bracket	1	3-218608	3-218608	6-218608
57	TCS	Valve	1	1-219330	1-219330	220496-2
58	TCS	Seat	1	1-038618	1-038618	1-310336
59	TCS	Seat Gasket, Teflon	1	1-038619	1-038619	1-038619
60	TCS	Body, Seat and Pin Assembly	1	227093-2	227093-2	227093-4
61	TCS	Bolt, 1/2-13 X 1-3/4	8	5-230958	5-230958	-
62	TCS	Flange	2	1-226166	1-226166	-
63	TCS	Flange Gasket	2	2-221453	2-221453	2-221453
64	TCS	Nut, 1/2-13	8	1-231174	1-231174	-

682 METER BODY REPAIR INSTRUCTIONS

I.

- A. Remove all parts and seals from the meter body and clean them. You may air blast parts with a glass bead material to clean parts.
- B. Always replace bracket (#56), screws (#54) & (#34), plunger cups (#38) and Rulon seals (#14, 17 & 44).
- C. Check for:
 - 1. Excessive wear on the wobble plate (#47) guide holes.
 - 2. Pitting on ball bearings (#49) & (#46).
 - 3. Excessive wear on the guide posts on main pivot bracket assembly (#53).
 - 4. Wear on the AF/SP valve (#57) or SS valve insert (#57).
 - 5. Wear on the valve seat (#58).
 - 6. Wrinkles on the sleeves in cylinders (TCS 1-126891) of the body.NOTE: Honing sleeves with Emory wheel may buff out wrinkles.

II.

- A. Mount valve seat (#58) to body (#60), with seat gasket (#59).
- B. Lap valve (#57) for AF, SP or SS.
 - 1. AF & SP – Use Rectorseal® Clover lapping compound or equivalent on valve (#57) & seat (#58). Move valve repeatedly in a Figure 8, and clean compound off valve and seat thoroughly when finished.
 - 2. SS – Use 220 & 320 grit silicon sand paper to lap valve & insert (#57). Move valve repeatedly in a Figure 8 on 220 grit paper, then use the 320 grit paper. Wipe valve Rulon insert clean.
- C. Replace plunger cups (#38) in piston (#40) and carefully place into cylinders. SEE PLUNGER CUP KIT for piston repair instructions. DO NOT cut or crimp plunger cups.
- D. Main Pivot & Wobble Plate Assembly.
 - 1. Screw the main pivot assembly (#50) all the way into main pivot bracket assembly (#53) and place pinion (#51) in its slot. For AF & SP meters, unscrew the pinion and main pivot bracket assembly 5 full turns. For SS meters, unscrew the pinion and main pivot bracket assembly 3 ½ full turns. This should help bring meter within range while calibrating.
 - 2. Drop the slotted screws (#54) into bracket.
 - 3. Place bracket with screws into main pivot bracket assembly.
 - 4. Set 5/8" ball bearing (#49) into position.
 - 5. Place the wear plate (#48) over the screws (#54).
 - 6. Set wobble plate (#47) onto the screws (#54) and fasten down with lock nuts (#41) & lock washers (#42).
 - 7. Set slack spring assembly (#45) on wobble plate post with Rulon washer (#44) & slack roller (#43).
 - 8. Mount main pivot bracket assembly to valve (#57) & seat (#58) with lock washers (#42) & screws (#52).
- E. Connect Pistons to Wobble Plate.
 - 1. Carefully slide connector (#36) over the wobble plate (#47) bearing seats.
 - 2. Place 1/2" ball bearing (#46) onto wobble plate and cover with bearing seat (#35) & retainer (#33).
 - 3. Rotate wobble plate (#47) & pistons (#40) through each cylinder to make sure of smooth flowing characteristics.

682 METER BONNET REPAIR INSTRUCTIONS

I.

- A. Remove all parts and seals from the meter bonnet and clean them. You may air blast parts with a glass bead material to clean parts.
- B. Check for excessive wear. NOTE: Problems with any of these following items will require a new bonnet or shafts.
 - 1. Drive Shaft (#5). Emory cloth may buff these out.
 - 2. Compensator Shaft (#24). Emory cloth may buff these out.
 - 3. Bonnet (#12)
 - a. Drive shaft packing gland.
 - b. Compensator shaft gland.
 - c. Counter drive gear assembly seat & post.

II.

- A. Insert drive shaft gear assembly (#18) with Rulon washer (#17) into the meter drive shaft packing. Install drive shaft packing Kit (#9).
SEE DRIVE SHAFT PACKING KIT INSTRUCTIONS for more information.
- C. Slide the counter drive gear assembly (#15) with Rulon washer (#14) over the post. Each meter uses about 3-4 washers (#10) before the cotter pin (#21) is inserted.
- D. Compensator Shaft Assembly
 - 1. Insert AF/SP retaining ring (#32) or SS cotter pin (#16) on to the compensator shaft (#24).
 - 2. Insert compensator shaft into packing gland.
 - 3. Install compensator shaft packing kit (#30).
SEE COMPENSATOR SHAFT PACKING KIT INSTRUCTIONS for more information.
- E. Mount Bonnet to Base.
 - 1. Place gasket (#13) into bonnet (#12).
 - 2. Move compensator shaft (#24) to match pinion (#51) in the base by using the index disc (#27).
 - 3. Mount bonnet (#12) to base (#60).
 - 4. Insert screws (#31) and tighten.

COMPENSATOR SHAFT SEAL KIT INSTRUCTIONS

- 1) Remove screws that bolt the meter cover assembly to the meter body. Loosen and remove the entire meter cover assembly.
- 2) Cut seal wire and remove seal pin from index disc.
- 3) Unscrew hex nut from the compensator shaft. Remove compensator washer, index disc, index plate and compression spring from the shaft.
- 4) From inside the cover housing, turn the compensator shaft until the attached truarc "E" retaining ring or cotter pin clears the edge of the counter drive gear. Slide the compensator shaft assembly from the housing.
- 5) Remove the spacer. Lift the old packing from the housing. Be sure there are no foreign particles left in the cavity.
- 6) Replace the compensator shaft assembly into the cover housing. Support the shaft from beneath while packing the new seal and spacer.
- 7) SEE ILLUSTRATION FOR PACKING SEQUENCE
- 8) Replace the compression spring, index plate, index disc, compensator washer and hex nut to the compensator shaft. Do not fully tighten the hex nut until the meter has been calibrated.
- 9) Reassemble the meter cover assembly to the meter body assembly and tighten down the screws. Calibrate the meter according to instructions.

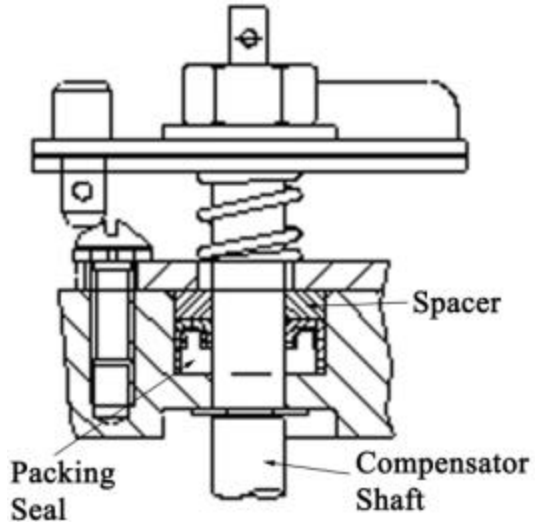

METER DRIVE SHAFT PACKING KIT INSTRUCTIONS

- 1) Remove screws that bolt the meter cover assembly to the meter body. Loosen and remove the entire meter cover assembly.
- 2) Carefully remove the roll pin from the drive shaft.
- 3) Remove (3) screws, (3) lock washers, and the compression washer.
- 4) From inside the cover housing, remove the retaining ring or cotter pin from the counter drive shaft. Remove the counter drive gear and washers. Slide the drive shaft assembly from the housing.
- 5) Lift the old packing from the housing. Be sure there are no foreign particles left in the cavity.
- 6) Replace the drive shaft assembly into the cover housing. Secure in position by reassembling the counter drive gear with the washers and retaining ring or cotter pin previously removed.
- 7) Support the counter drive shaft assembly from beneath while packing the spacer bearings, washers and the new seal.
- 8) SEE ILLUSTRATION FOR PACKING SEQUENCE
- 9) Replace the compression washer with the screws and lock washers.
- 10) Insert the roll pin in the drive shaft. Be sure to support the shaft while doing this to prevent bending it.
- 11) Reassemble the meter cover assembly to the meter body assembly and tighten down the screws.

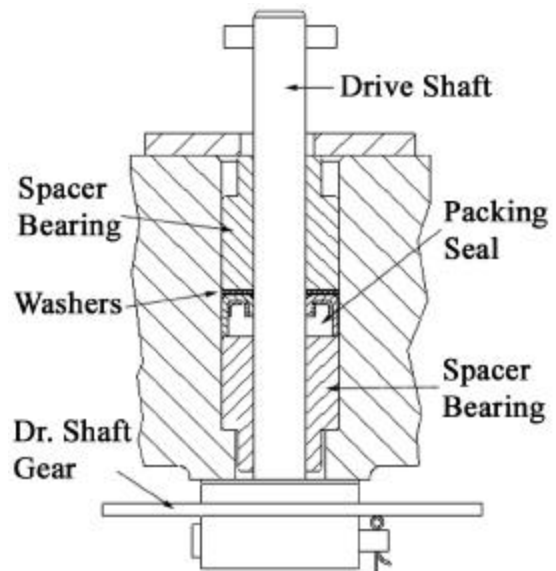

PLUNGER CUP REPLACEMENT

- 1) Remove plunger assembly from meter body.
- 2) Loosen and remove two (2) round head screws and lift plunger cup support from plunger cup and plunger disc.



- 3) Discard the old plunger cup kit
- 4) Place the new plunger cup on the plunger disc. Add the cup support and secure with the two (2) round head screws previously removed.



NOTE: Apply Loctite 271 (or equivalent) to the screw threads. Be sure the cup is evenly spaced on the plunger disc and support.

- 5) Form the cup by turning the plunger assembly in your hand using your thumb to roll the edge slightly.



- 6) After the cup is partially formed, place the plunger assembly into the meter body and press into the piston cylinder.



- 7) Turn the assembly in the piston cylinder to assure the cup is evenly formed to the cylinder.
- 8) Replace previously removed parts and reassemble meter. Test and calibrate meter for accuracy.

AIR ELIMINATOR ASSEMBLY

640-15

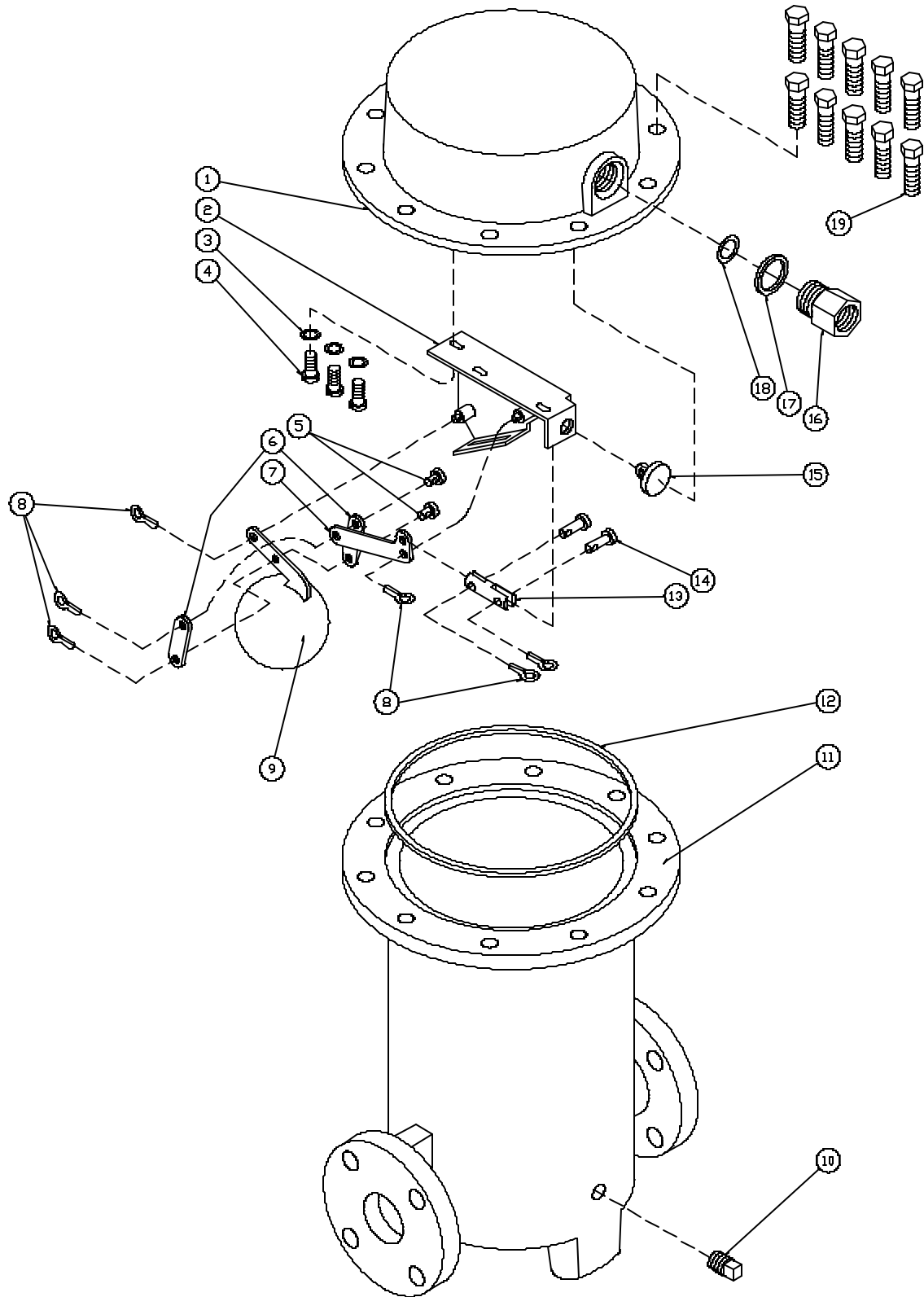

AIR ELIMINATOR ASSEMBLY

640-15

ITEM#	DESCRIPTION	QTY	AF	SS
1	Cover	1	64002-2	64002-3
2	Bracket Assembly	1	64019	64019
3	Lock Washer	3	1-126316	1-126316
4	Screw	3	64010	64010
5	Short Link Pin	2	64023	64023
6	Connecting Arm	2	64007	64007
7	Lever Arm	1	64006	64006
8	Cotter Pin	6	1-126318	1-126318
9	Float Assembly	1	64005	64005
10	Pipe Plug	1	2-051913	2-126146
11	Base	1	64003-2	64003-3
12	Gasket	1	64004	64004
13	Shut Off Arm	1	64015	64015
14	Long Link Pin	2	64012	64012
15	Shut Off Valve	1	64016	64016
16	Valve Seat	1	64001	64001
17	External Valve O-Ring	1	64013	64013
18	Internal Valve O-Ring	1	64014	64014
19	Screw	10	64021	64021

640 AIR ELIMINATOR REPAIR INSTRUCTIONS

- 1) Remove the screws (#19) that bolt the air eliminator base (#11) to the cover assembly (#1).
- 2) Remove the screws (#4) and washers (#3) that mount the float and bracket assembly (#2) to the cover assembly (#1). Inspect for damage to float and bracket assembly, making sure no liquid is inside the float (#9) and o-rings (#17 & 18) are not torn or cut. All foreign particles must be removed (i.e. dirt, metal shavings, ...)
- 3) Replace all damaged air eliminator parts.
- 4) Reassemble the float and bracket assembly to the cover assembly with screws (#4). Do not tighten screws until the bracket assembly (#2) is properly adjusted between the shut-off valve (#15) and seal (#18).
- 5) Once float and bracket assembly are tightened, reassemble air eliminator.

HYDRAULIC VALVE ASSEMBLY

650-15

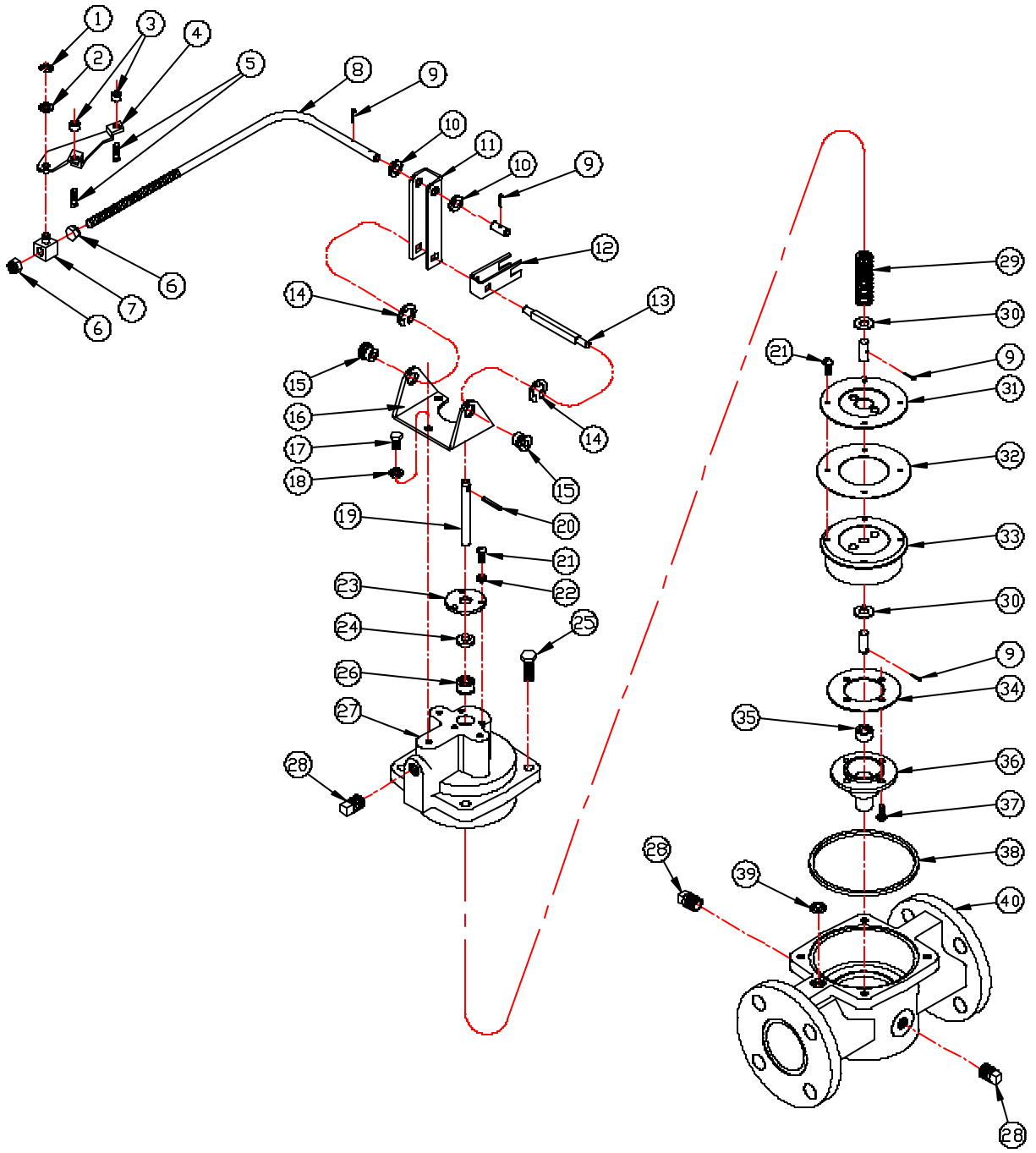

HYDRAULIC VALVE ASSEMBLY

650-15

ITEM#	DESCRIPTION	QTY.	AF	SS
1	Retaining Ring	1	6-052482	6-052482
2	Washer, Flat	1	65034	65034
3	Spacer	2	1-130852	1-130852
4	Preset Bracket	1	1-226102	1-226102
5	Screw	2	65005	65005
6	Locknut	2	65008	65008
7	Swivel Block	1	1-128140	1-128140
8	Connecting Link	1	65025	65025
9	Cotter Pin	4	1-126318	1-126318
10	Washer	2	65003	65003
11	Actuating Arm	1	65016	65016
12	Lifter	1	65010	65010
13	Valve Handle Shaft	1	65005	65005
14	Retaining Ring	2	65026	65026
15	Shaft Bearing	2	65004	65004
16	Bracket	1	65012	65012
17	Screw, 1/4-20 X 1/2	3	65032	65032
18	Washer, Split Lock	3	1-126317	1-126317
19	Valve Stem	1	65018	65018
20	Roll Pin, 5/32 X 1	1	65027	65027
21	Screw, 10-24 X 1/2	7	1-128279	1-128279
22	Washer	3	1-126316	1-126316
23	Compression Washer	1	1-130872	2-130872
24	Spacer	1	1-130893	1-130893
25	Screw, 5/16-18 X 1	4	65033	65033
26	Packing Seal	1	600102	600102
27	Cover	1	65031-2	65031-4
28	Pipe Plug	3	2-051913	2-126146
29	Poppet Spring	1	65007	65007
30	Washer, Flat	2	65035	65035
31	Plunger Cup Support	1	65014	65014
32	Plunger Cup	1	65013	65013
33	Plunger	1	65030	65030
34	Valve Disc	1	65009	65009
35	Valve Seat	1	65006	65006
36	Poppet Guide	1	65029	65029
37	Screw, 10-24 X 5/8	4	1-128279	1-128279
38	Gasket	1	65021	65021
39	O-Ring	1	65001	65001
40	Valve Body Assembly	1	65036-1	65036-2

650 HYDRAULIC VALVE REPAIR INSTRUCTIONS

- 1) Remove the screws (#17) from the bracket (#16) and lift the arm linkage from the valve assembly.
- 2) Remove the roll pin (#20) from the valve stem (#19). Then remove the screws (#25) from the cover (#27) and poppet assembly and lift from the body (#40).
- 3) Inspect the seat of the body (#40) for pitting or foreign matter. Pull the poppet assembly from the cover (#27) and inspect for a damaged plunger cup (#32) and/or valve disc (#34).
- 4) Remove the screws (#37) from the poppet guide (#36) to inspect the valve seat (#35) for pitting or excessive wear. Replace as necessary.
- 5) To replace the packing seal (#12) within the cover (#27), remove the compression washer (#23), screws (#21), washers (#22) and stem (#19) completely. Carefully slide packing seal (#12) and spacer (#24) over valve stem (#19). Reassemble compression washer, screws and washers.
- 6) Replace the previously removed parts and reassemble the valve.

682 METER EXCLUSIVE LIMITED WARRANTY

WARRANTY

New 682 piston meters manufactured by Total Control Systems, a division of Murray Equipment, Inc. ("TCS") with which this warranty is enclosed, are warranted by TCS to the original purchaser only for a period of ten (10) years from the date of shipment, to be free, under normal use and service, from defects in material and workmanship. TCS manufactured new equipment or components are warranted for a period of one (1) year from the date of shipment, under normal use and service. This warranty is extended only to the original purchaser. For defects occurring within the stated warranty period, TCS will repair or replace, at TCS's option; provided that part or parts are returned to TCS transportation charges prepaid, and the TCS's examination discloses the parts or workmanship to have been defective upon delivery to the purchaser.

EXCLUSIONS

TCS's ten (10) year warranty applies to meters only and does not apply to accessories such as valves and air eliminators. Parts and equipment not manufactured by TCS may be covered by separate warranties of their respective manufacturers. This warranty does not cover any parts or equipment not manufactured by TCS or related companies. This warranty does not extend to any equipment that has been altered in any way, subjected to misuse, negligence, accident, or if operated in any manner other than in accordance with TCS's operating instructions or have been operated under conditions more severe than, or otherwise exceeding those set forth in the specifications. General maintenance, calibration, clean up and normal wear is excluded from this limited warranty.

CLAIM PROCEDURES

In order to obtain performance by TCS of its obligations under this warranty, the original purchaser must obtain a Return Goods Authorization (RGA) number from TCS's customer service department within 30 days of discovery of a purported breach of warranty, but not later than the expiration of the warranty period. Once authorization is received, return the defective meter, piece of equipment, or component covered by this warranty, with transportation charges prepaid, to TCS at the address shown below together with a written statement setting forth the nature of the defect and RGA number.

LIMITATIONS

THERE ARE NO OTHER WARRANTIES OF ANY KIND, EXPRESS OR IMPLIED. TCS SPECIFICALLY DISCLAIMS ANY WARRANTY OF MERCHANTABILITY OR OF FITNESS FOR ANY PARTICULAR PURPOSE. TCS will determine if all parts or meter defect falls within the warranty guidelines and will repair or replace within a reasonable time span. TCS is not responsible for any in or out bound freight. TCS's sole obligation that shall represent the buyer's sole and exclusive remedy shall be to repair or at TCS's option to replace any product or part determined to be defective. In no event shall TCS be liable for any special, direct, indirect, incident, consequential or other damages of similar nature, including without limitation, loss of profits, products, production time, or loss of expenses of any nature incurred by the buyer or any third party. TCS has not authorized on its behalf any representation or warranties to be made, nor any liability to be assumed except as expressly provided herein; there is no other express or implied warranty.

REPAIR WARRANTY

All repair work is warranted for (90) days from the date of shipment to customer. Some parts may be warranted for longer periods by the Original Equipment Manufacturer.

DESIGN AND EQUIPMENT CHANGES

Any changes in design or improvements added shall not create any obligation to install same on equipment previously sold or ordered.

TOTAL CONTROL SYSTEMS
2515 Charleston Place • Fort Wayne, IN 46808
(800) 348-4753 • (260) 484-0382 • Fax (260) 484-9230
sales@tcsmeters.com • www.tcsmeters.com