



VEEDER-ROOT
INSTALLATION, OPERATION
AND SERVICE INSTRUCTIONS

Technical Manual
8-012
Issued: 7/96
Supersedes: 6/93

METER PRINTER

SERIES 788800 (ZERO START)

&

SERIES 788801 (ACCUMULATIVE)

Includes INSTALLATION INSTRUCTIONS FOR
KITS 312020-357, -423, -675, AND -893

Manual No. 251322, Rev.B

COMPANY IMPRINT

Date _____

Sold to _____

Address _____

AUTOMATICALLY PRINTED  TO ASSURE YOU OF ACCURACY

MASTER WITH RECEIPT

OPERATOR	Cash	TRUCK NO.
Charge		

YOUR SALE NO. GALLON READING - FIFTY

AA 9 0 3 0 1 7 6

AA 9 0 2 0 1 7 3

PREVIOUS SALE NO. GALLON READING

GALLONS DELIVERED

PRODUCT	GALS.	PRICE

RECEIVED QUANTITY SHOWN ABOVE RECEIVED PAYMENT

CUSTOMER SIGN HERE AFTER DELIVERY

INSERT FACE DOWN  THIS SIDE

PRINTED IN U.S.A.





TABLE OF CONTENTS

SECTION 1. INTRODUCTION

A. General	1
B. Damage Claims	1
C. Return Shipping	1

SECTION 2. DESCRIPTION

A. Operation of Zero Start Printer	1
B. Operation of Accumulative Printer	1

SECTION 3. PRINTER REMOVAL AND INSTALLATION

A. Removal	3
B. Installation	3

SECTION 4. CLEANING AND LUBRICATING

A. General	3
B. Cleaning	3
C. Recommended Lubrication	3
D. Lubricating Points	5

SECTION 5. TROUBLESHOOTING

A. General Checks	6
B. Troubleshooting	8
C. Ticket Position Adjustment	8
D. Sales Number Advancing Mechanism Inspection	9
E. Right-Hand Wheel Inching Mechanism Adjustment	10

SECTION 6. REPAIR AND REPLACEMENT

A. Ticket Tray Removal	10
B. Wheel Removal	11
C. Wheel Installation	11
D. Ticket Tray Installation	11
E. Reset Gears Replacement Timing of Printer	11

SECTION 7. INSTALLATION INSTRUCTIONS FOR KITS 31202-357, -423, -675, AND -893

A. Introduction	12
B. Parts List	12
C. Installation Instructions	12
D. Operational Check	13

SECTION 8. DAMAGE CLAIMS, WARRANTY AND CONDITIONS

A. Warranty	13
B. Inspection	13
C. Limitation of Remedy and Warranty	13
D. Limitation of Damages	13
E. Limitation of Actions	13
F. Collateral Promises	13
G. Interpretation	13



SECTION 1. INTRODUCTION

A. GENERAL. These instructions are for servicing of the Series 7888 Meter Printer, Figure 1, designed and manufactured by Veeder-Root Company, 6th Avenue at Burns Crossing, Altoona, PA 16602, P.O. Box 1673, Altoona, PA 16603. Phone: (814) 695-4476.

Note: Consult Veeder-Root on any unusual application, installation or possible modification of this basic design.

When a vertical bar **|** appears adjacent to text or illustrations, information has been added or changed at the last issue date.

Every Meter Printer is thoroughly tested at the Veeder-Root factory and by the meter manufacturer when installed on the meter. However, like any precision mechanism, it requires periodic care to ensure maximum service. This manual is for use in areas where factory rebuilding facilities and adequate exchange stocks are not readily accessible.

Where manufacturer's replacement stocks are available, it is important that no attempt be made to repair any printer that is defective within the terms of the warranty as, by doing so, the warranty is void and the user is deprived of protection as provided by the warranty. It is recommended that, when possible, printers be replaced and the defective unit returned to the meter manufacturer.

Note: See Section 8 for complete Warranty and Conditions.



Figure 1. Series 7888 Meter Printer Mounted on Series 7887 Meter Register

B. DAMAGE CLAIMS.

1. Thoroughly examine all components and units as soon as received. If damaged, write on the face of the freight bill a complete and detailed description of the damage. Have the carrier's agent sign the description.

Note: Insist that the carrier's agent verify the inspection and sign the description.

2. Immediately notify the delivering carrier of damage or loss. This notification may be given either in person or by telephone. Written confirmation must be mailed within 48 hours. Railroads and motor carriers are understandably reluctant to make adjustments for damaged merchandise unless inspected and reported promptly.
3. Title to damaged merchandise remains with the buyer. It is the buyer's responsibility to file a claim with the carrier involved.

4. Immediately advise your Veeder-Root representative, distributor, or the factory so that we may assist you. We will cooperate in every possible way.

C. RETURN SHIPPING. All shipments of Veeder-Root products must be prepaid. Equipment must be packed in a strong exterior container and surrounded by at least six inches of shock-absorbing material. Veeder-Root will accept no liability for damage caused by improper packing. It is suggested that the original shipping container be used if it is available. Address shipment to Service Department, Veeder-Root, 6th Avenue at Burns Crossing, Altoona, Pa. 16603.

SECTION 2. DESCRIPTION

A. OPERATION OF ZERO START PRINTER. The Series 788800 Meter Printer (Zero Start) mechanically records and prints digital information delivered to its drive shaft. This shaft positions the print wheels according to the ratio of internal and external gears. Reset and print operations are manually actuated.

The Zero Start Meter Printer is so named because it begins the count at zero and returns to zero when reset. The printed total is the amount of the delivery.

1. **Drive.** The shaft, Figure 2, on the bottom of the printer is driven by a bevel gear from a meter register or other equipment. The printer's bevel gear and shaft assembly turns in a counterclockwise direction. The internal bevel gear on the shaft drives the clutch assembly, associated pinions and the gear assembly of the right-hand print wheel.

Note: The zero start clutch assembly prevents the print wheels from turning in a reverse direction.

2. **Reset.** During printing operation, the print wheels, Figure 2, are reset to zero through rotation of the reset gear train and reset shaft, Figure 3. During the "Print In" cycle, one complete clockwise revolution of the reset drive gear turns the reset shaft gear and reset shaft to reset the print wheels to zero.

3. **Printing.** In printing operation, a ticket is inserted into the slot of the ticket tray until it bottoms on the internal stop.

- a. As the printing knob is turned, the reset drive gear, Figure 3, makes one complete clockwise revolution until a positive stop is reached. As the ticket tray moves into position, the seal pin pierces the ticket, holding it in place. This initial printing is made with wheels at zero.
- b. At the completion of delivery, the knob is turned in a clockwise direction one complete turn until the stop is again reached. During this cycle the second printing is made recording the amount of delivery. At the end of the print cycle, the ticket tray returns to its original position and the seal pin releases the ticket.

B. OPERATION OF ACCUMULATIVE PRINTER.

The Series 788801 Meter Printer (Accumulative) mechanically records and prints digital information delivered to its drive shaft. This shaft positions the print wheels according to the ratio of internal and external gears. Print operations are manually actuated.

The Accumulative Meter Printer is so named because it is a non-resetting type that begins the count at the accumulated total of the last delivery, prints it, accumulates a new total for the new delivery and prints it. The amount delivered must be calculated by the operator.

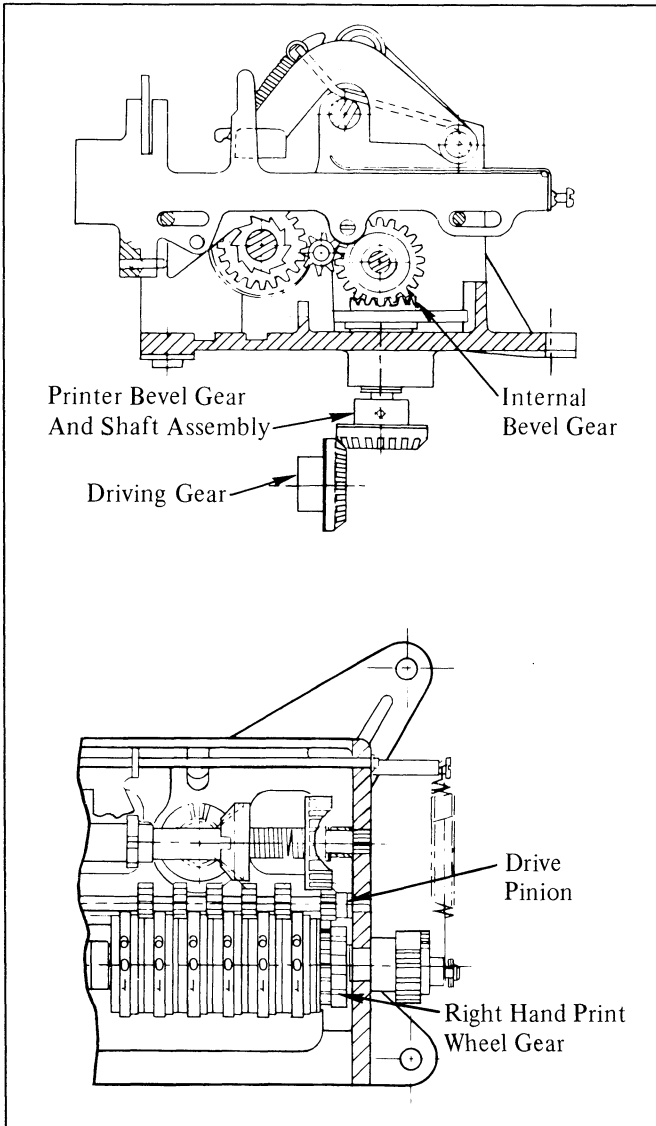

Figure 2. Drive Train (Zero Start)

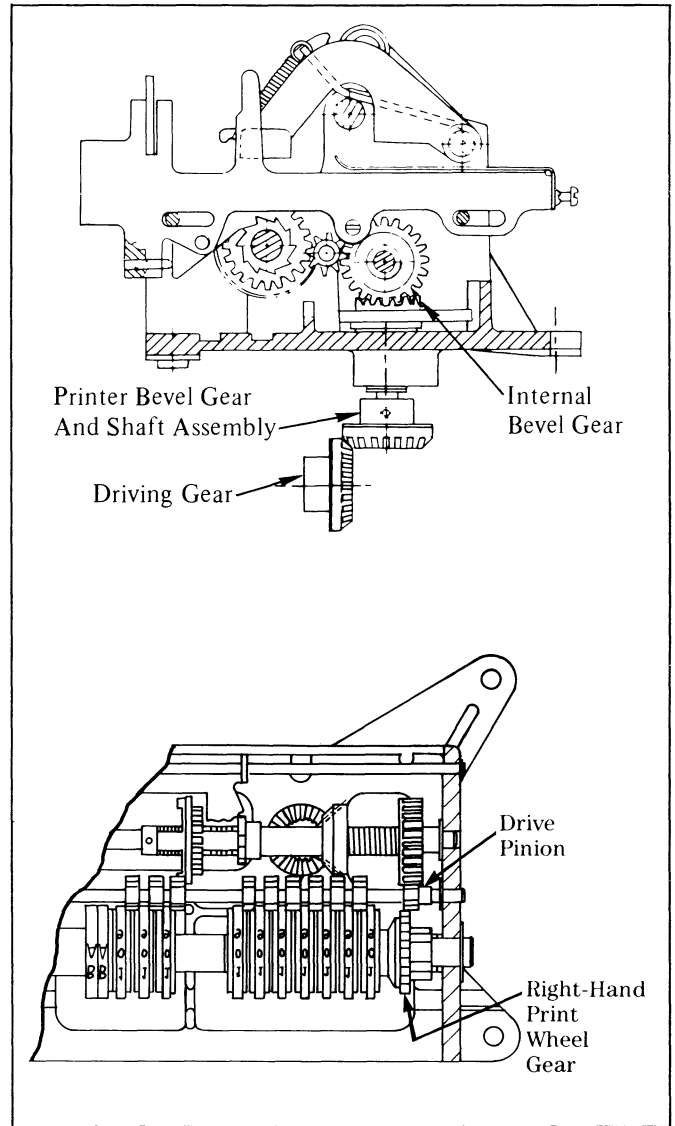

Figure 4. Drive Train (Accumulative)

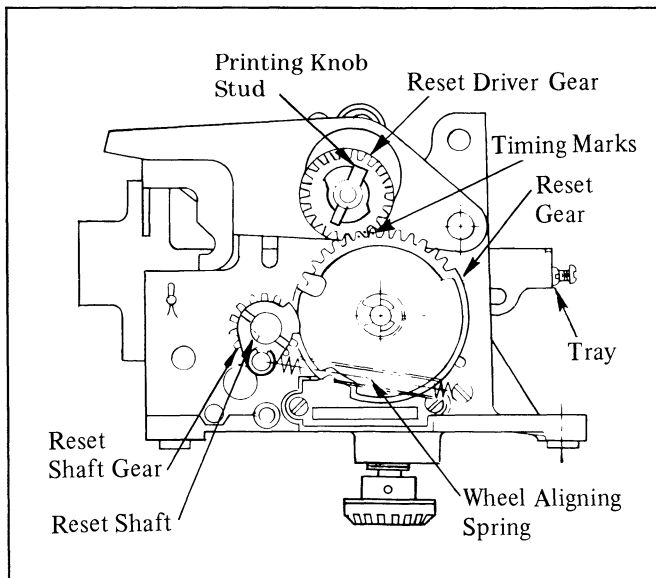

Figure 3. Reset Train (Zero Start)

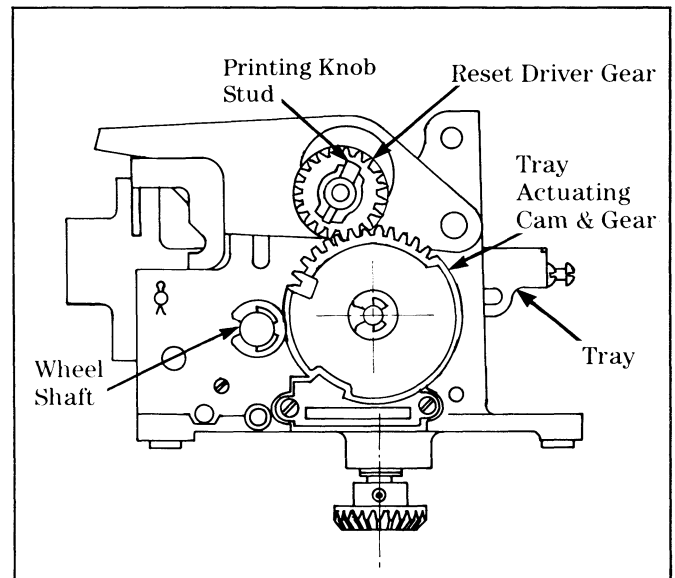

Figure 5. Tray Actuating Train (Accumulative)



1. **Drive.** The shaft, Figure 4, on the bottom of the printer is driven by a bevel gear from a meter register or other equipment. The printer's bevel gear and shaft assembly turns in a counterclockwise direction. The internal bevel gear on the shaft drives the clutch assembly, associated pinions and the gear assembly of the right-hand print wheel.
2. **Printing.** In printing operation, a ticket is inserted into the slot of the ticket tray until it bottoms on the internal stop.
 - a. As the printing knob is turned, the reset drive gear, Figure 5, makes one complete clockwise revolution until a positive stop is reached. As the ticket tray moves into position, by means of the tray actuating cam and gear, the seal pin pierces the ticket, holding it in place. This initial printing is made with wheels as they were at the completion of the last delivery.
 - b. At the completion of delivery, the knob is turned in a clockwise direction one complete turn until the stop is again reached. During this cycle the second printing is made recording the accumulative total of this delivery. At the end of the print cycle, the ticket tray returns to its original position and the seal pin releases the ticket.

8. Install printer cover using four corner bolts under the register.
9. Install the large steel washer, then the rubber washer on the slotted end of the shaft extension.
10. Insert shaft extension with washers through hole in cover and engage the end of reset shaft.
11. Position reset knob with arrow pointing up, approximately vertical, on spline of shaft extension and secure to printer with the 2¼ inch flat-head screw.
12. Check operation of assembly for input torque and printing of ticket.
13. Seal units with wire through holes in corner bolts.

SECTION 3. PRINTER REMOVAL AND INSTALLATION

A. REMOVAL. Before maintenance, remove the printer from the meter register as follows:

1. Break the seal and remove four bolts on the bottom corners of the meter register.
2. Remove the screw from the center of the printer knob and remove knob, shaft extension and washers from the printer. Remove the cover.
3. Remove the bolts securing the printer frame to the meter register. Remove the printer.

B. INSTALLATION. After maintenance, install the printer onto the meter register as follows:

1. If the meter register is still in the case, remove the three screws holding it and lift the register from the case. Reset the register to zero by turning the small gear at the left end of the reset shaft counterclockwise.
2. Install printer knob and shaft extension on printer and turn it until tray is in the outward position and seal pin down. Remove printer knob and shaft extension.
3. Rotate the large idler gear (B) so that the timing marks on it and the printer gear (A) align. See Figure 6. It may be necessary to hold the idler gear in position until the printer is mounted and the idler gear and print gear engage.
4. Mount the printer onto the meter register and secure with bolts.
5. Check the position of the timing marks on the printer gear (A), idler gear (B) and register gear (C). They must be in the position shown in Figure 6.
6. Loosen the printer bevel gear set screw and adjust for proper backlash between the printer bevel gear and the meter register drive gear as necessary (Figure 20).
7. Place assembly in register case and secure with three screws.

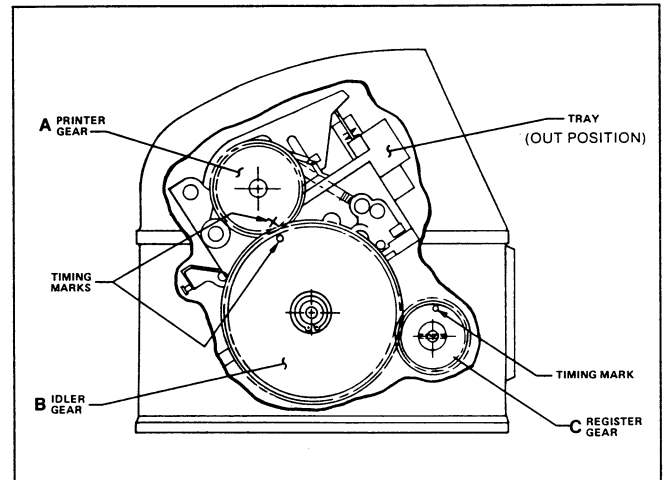

Figure 6. Assembling Printer to Meter Register

SECTION 4. CLEANING AND LUBRICATING

A. GENERAL. Although the printer is adjusted and lubricated when manufactured, it does require periodic cleaning and lubrication to give maximum service. Judgment of the intervals at which the printer requires such service must necessarily be left to individual users due to varying conditions of service. Under normal conditions, this will be no more than twice a year or after each 100,000 units of measure delivered.

B. CLEANING.

1. Remove cover and detach printer from meter register per Section 3.
2. Flush printing wheels, reset gears, and all drive gears with cleaning solvent. Blow out surplus solvent with compressed air and lubricate unit.
3. If printing wheels are extremely dirty, a small brush may be used to scrub the figures.

CAUTION: DO NOT USE A WIRE BRUSH.

C. RECOMMENDED LUBRICATION.

Note: Chemlube and Vischem products are manufactured by Ultrachem Inc., 1400 N. Walnut St., P.O. Box 2053, Wilmington, DE 19899.

Oil: Chemlube 201 or equivalent with a temperature range of -65° to +275°F (-54° to +135°C).

Grease: Vischem 352 or equivalent with a temperature range of -65° to +300°F (-54° to +149°C).



Installation, Operation and Service Instructions Series 7888 Meter Printer

Note: All lubricants used in the printer must be of a type which remains fluid over the full temperature range to which the printer will be subjected. Also, they should not oxidize or dry out leaving a gummy or perceptible residue.

If the Chemlube oil lubricant is not available, a substitute with equivalent properties may be used. To assist field people in obtaining suitable lubricants for the printers, the following list showing equivalent lubricants has been prepared:

	OIL	
AEROSHELL FLUID		NO. 3
REGENT SPINTEX OIL		60
GARGOYLE ARCTIC OIL		LIGHT
CASTROL HYSPIN		40
	GREASE	
AEROSHELL		14
ESSO BEACON		325

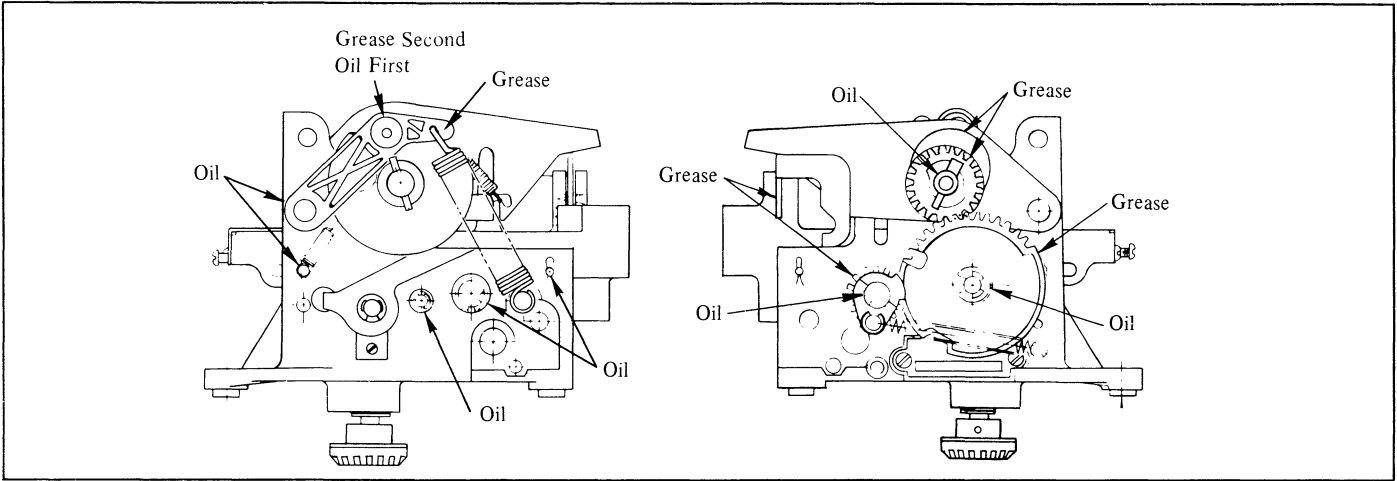

Figure 7. Lubrication Points - Zero Start Printer

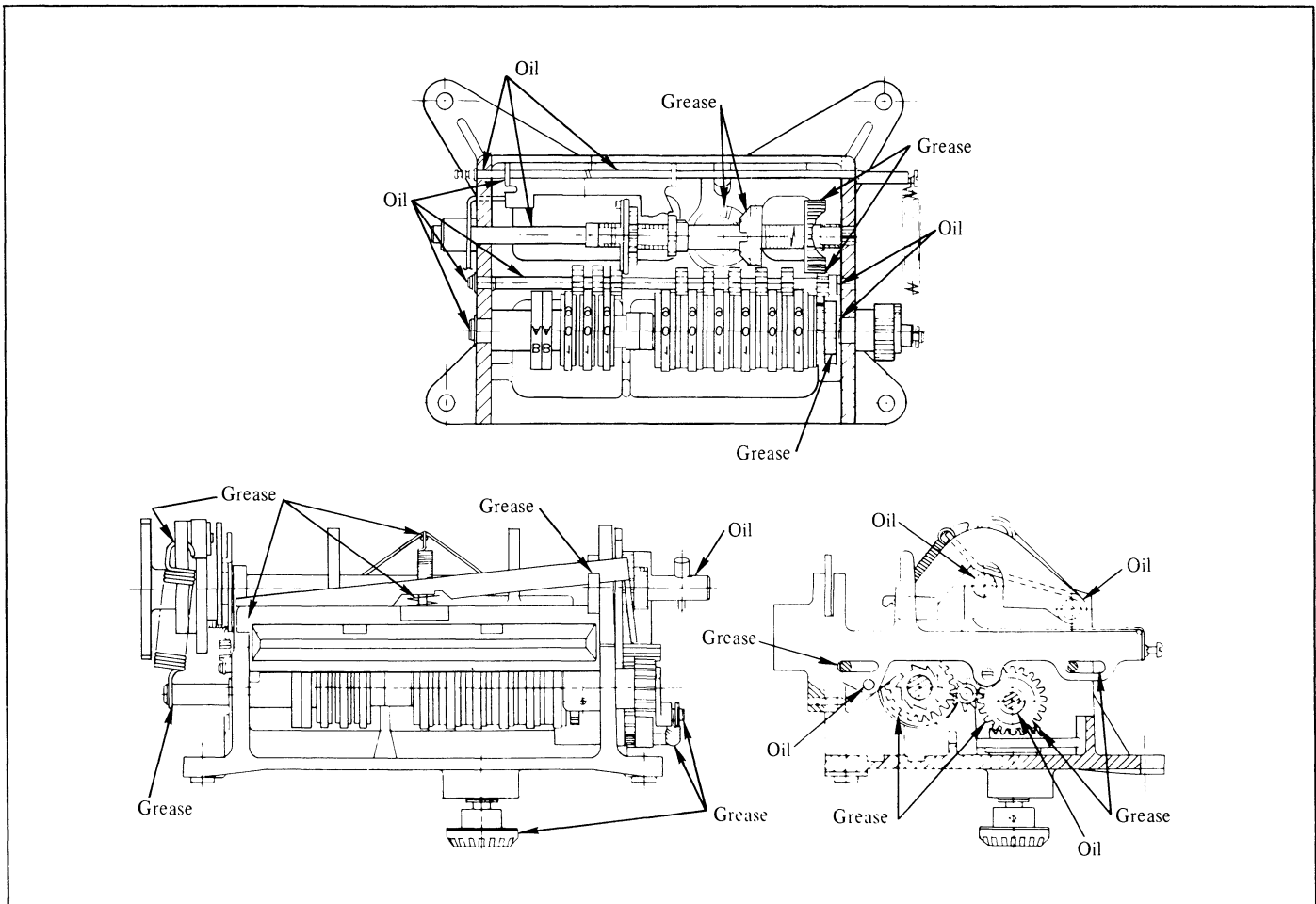

Figure 8. Lubrication Points - Zero Start Printer

D. LUBRICATION POINTS (Figures 7 to 10).

1. Apply recommended or equivalent oil to bearing surfaces of all shafts, studs, and bosses on which parts move or rotate.
2. Apply recommended or equivalent grease to bearing and mating surfaces of all bevel gears, drive gears, reset gears, wheel ratchets, ticket tray, shafts, studs, and bosses according to Figures 7 to 10.

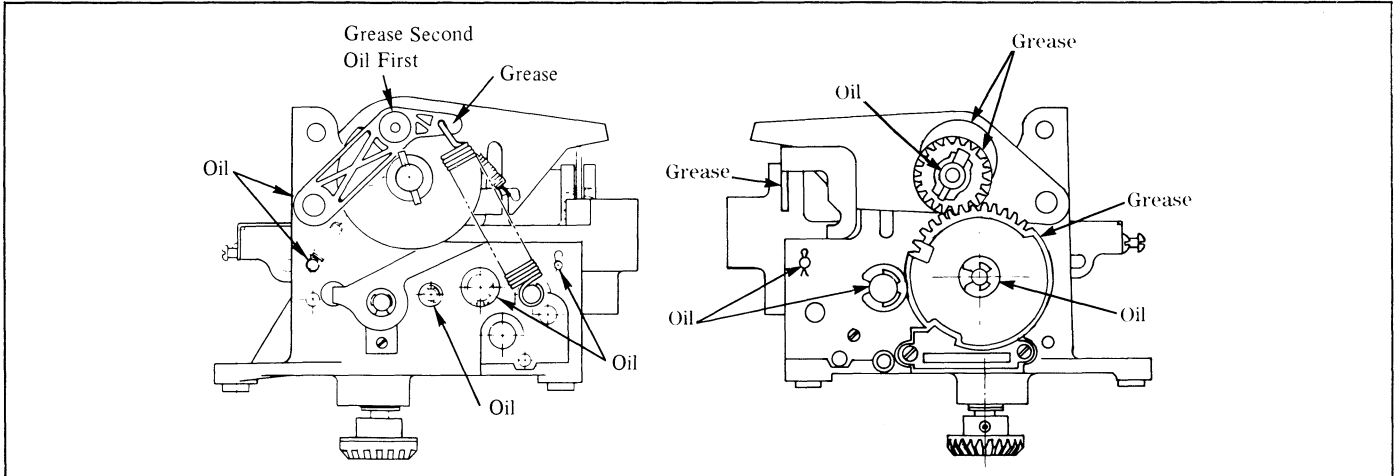

Figure 9. Lubrication Points - Accumulative Printer

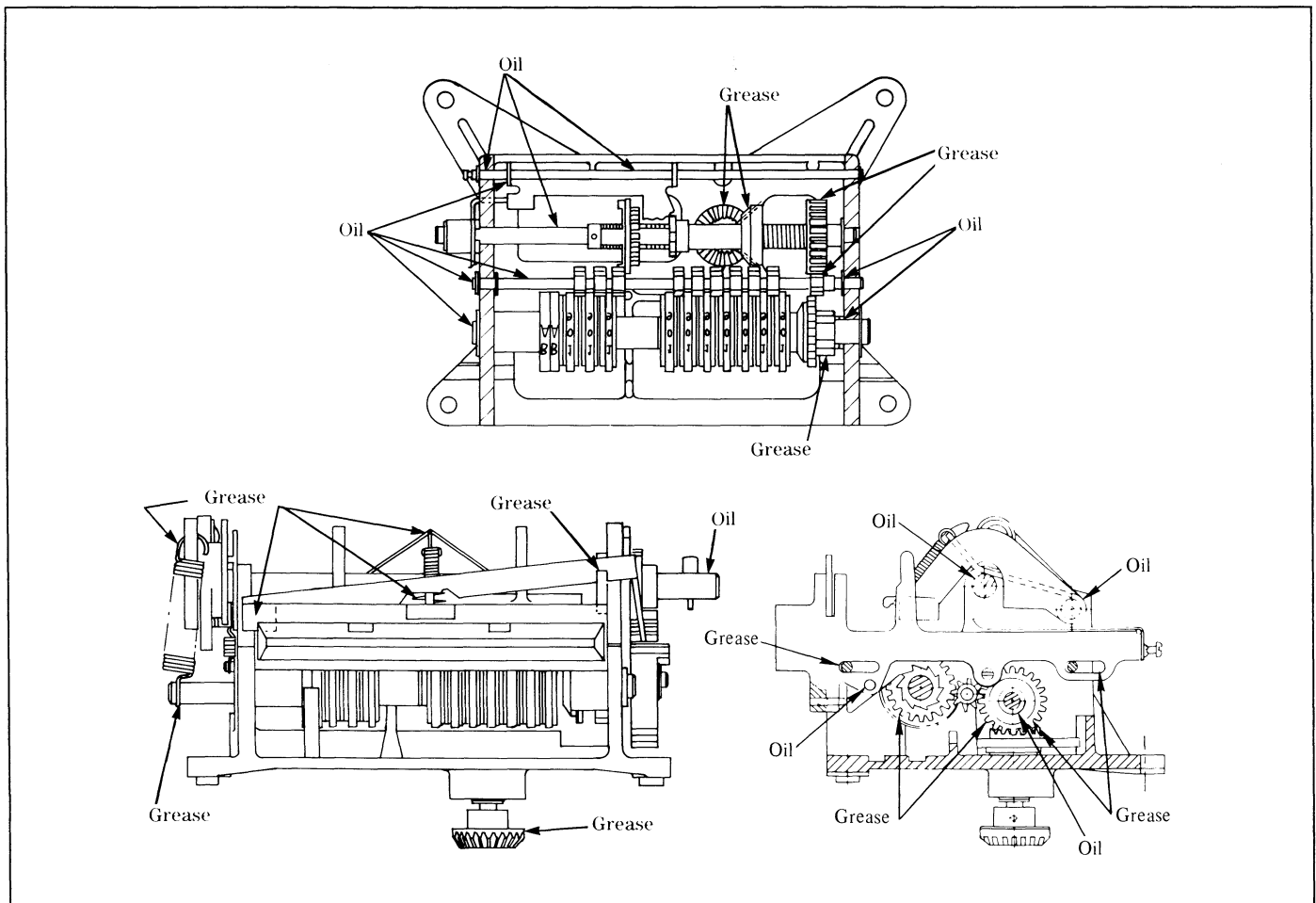

Figure 10. Lubrication Points - Accumulative Printer



SECTION 5. TROUBLESHOOTING

A. GENERAL CHECKS. (Figures 11 through 15). If the reason for the trouble is unknown, it is necessary to examine the printer to locate and replace malfunctioning parts.

1. Observe function of the no-back pawl by turning the knob in a counterclockwise direction. The no-back pawl should limit the rotation to 20 degrees.
2. Turn the knob in a clockwise direction. The one-turn stop pawl should stop the knob after one complete turn.
3. Turn knob until tray is in rear position and seal pin is up.
4. While turning the knob, observe the following during the "Print In" cycle:
 - a. Tray moves forward to "Print In" position and seal pin pierces ticket (wheels reset to zero on Zero Start model only).
 - b. Print action occurs before stop.
 - c. Simulate delivery by turning drive gear. While delivery is being made, sales number wheel advances one digit.
5. Observe the following during the "Print Out" cycle:
 - a. Tray moves to rear of printer.
 - b. "Print Out" occurs showing the quantity delivered.
 - c. Seal pin releases ticket before stop is reached.
6. Check print wheel end play for 0.020 to 0.025 inches.
7. Turn the printer so the printing arm faces you. Check the springs to see that they are properly anchored.
8. Check roller on the printing arm for proper alignment on cam.
9. Examine stop pawl for proper assembly.
10. Turn the printer so the back faces you. Be sure the ticket stop screw is secure.
11. Check the tray support rods to be certain they are free and secured in place by four clips.
12. Turn the printer so the knob faces you. Be sure the springs are properly anchored (omit for Accumulative Printer).
13. Examine the E-ring retainers and pins to be certain that they are properly seated and tight.
14. Examine the three reset gears for damage or wear. Replace as required.

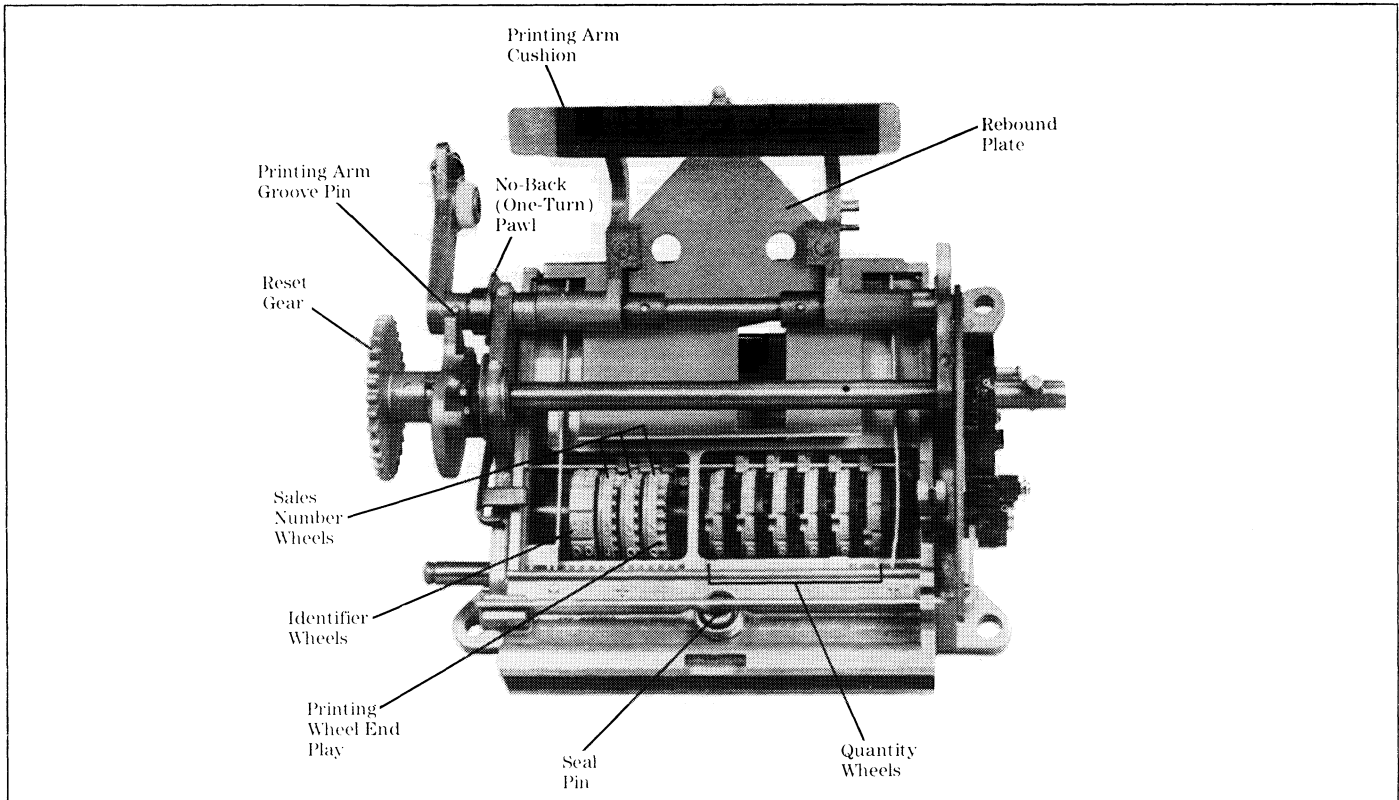

Figure 11. Parts Identification

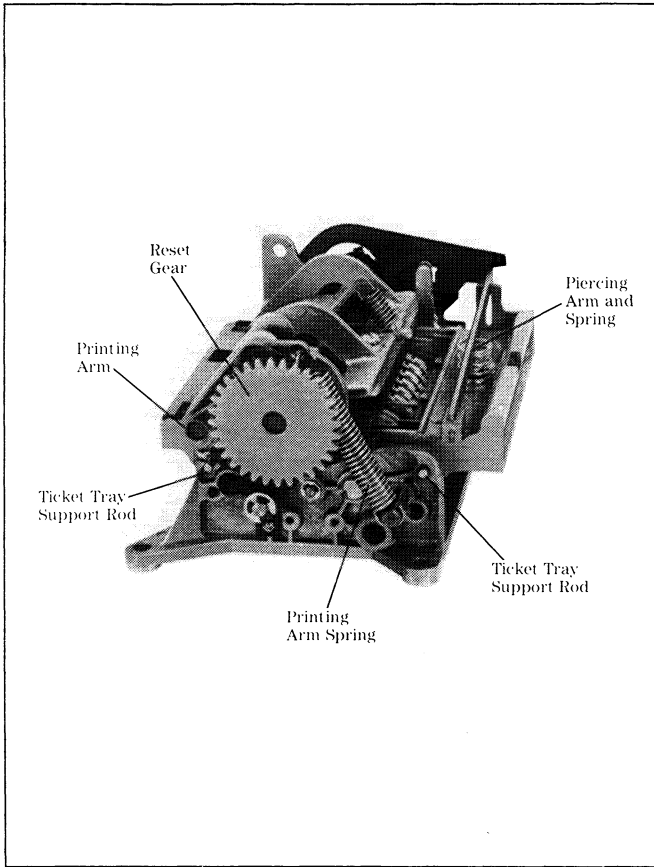

Figure 12. Parts Identification

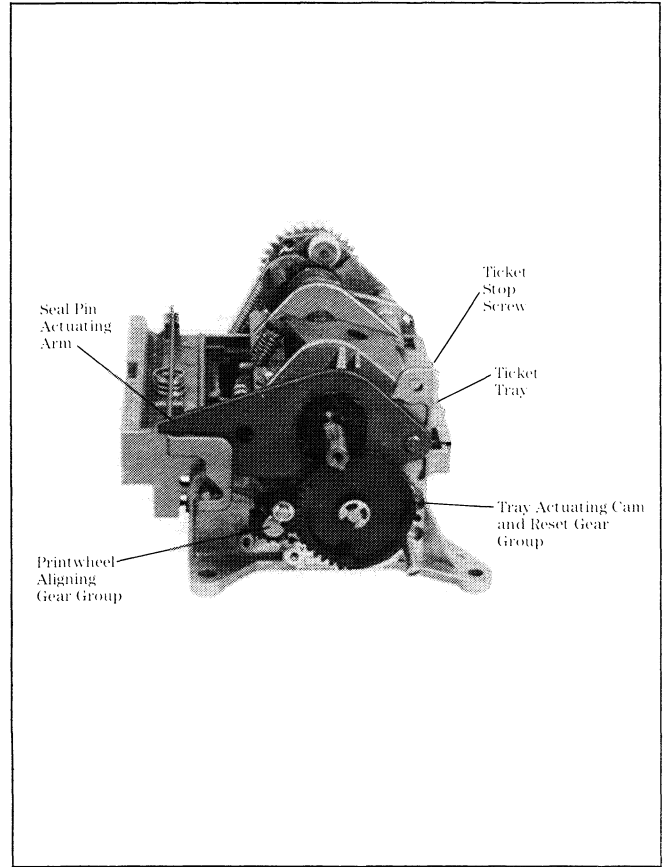

Figure 13. Parts Identification

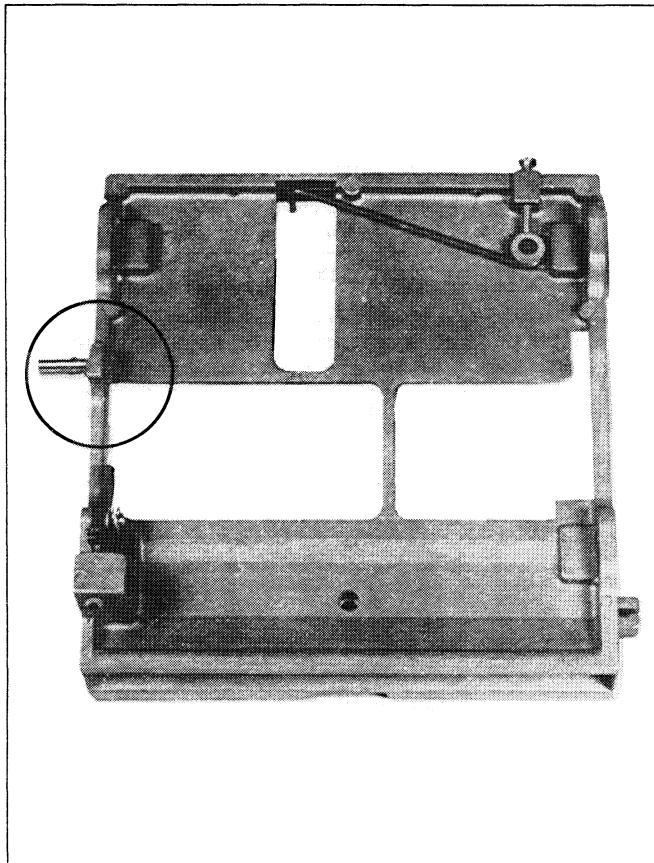

Figure 14. Ticket Tray Actuating Pin

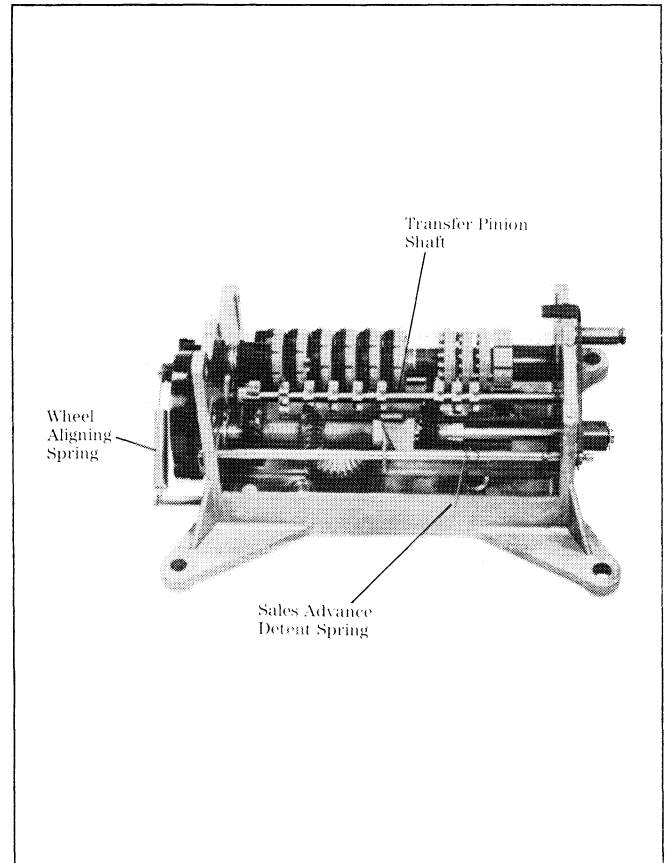

Figure 15. Sales Advance Mechanism



Installation, Operation and Service Instructions Series 7888 Meter Printer

B. TROUBLESHOOTING. Tables 1 and 2 are used to assist in locating problems and making minor repairs and corrections in the field. In some problems, similar defects can be produced by several causes of entirely different nature. Cause of the trouble must be determined and the correction made.

C. TICKET POSITION ADJUSTMENT. When print is out of position on the ticket, the tray stop and guides must be adjusted.

1. To adjust the depth of the ticket, loosen the ticket stop set screw on the rear of the ticket tray (see Figure 16). Move the stop forward or rearward, as required, then tighten the set screw.
2. To adjust the lateral position of the ticket, remove the two ticket shield screws and shield. Move the guides in notches to position the ticket properly, then replace shield and screws.

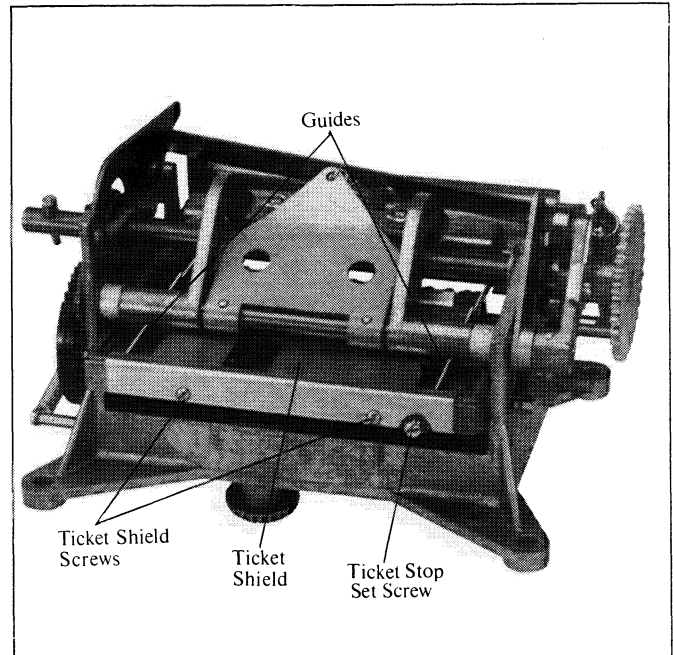

Table 1. Troubleshooting For Zero Start Meter Printer

Figure 16. Ticket Position Guides and Stop Screws

TROUBLE	POSSIBLE CAUSE	CORRECTION
Printing knob turns hard.	Burrs on reset gears or teeth are damaged (Figure 13).	Check reset gear group. Replace defective gears.
Printing knob binds.	Bent ticket tray actuating pin (Figure 14).	Straighten or replace the tray.
Printing knob fails to stop after making one complete turn.	One-turn stop pawl may be bent. Spring may be missing (Figure 12).	Straighten pawl or replace spring.
Printing knob binds at one area of reset cycle.	Printing arm cam groove pin not seated properly (Figure 11).	Seat the groove pin properly.
Reset shaft jams.	Reset gears may be out of time.	Check reset gears and time as required. See Section 6.
Wheels fail to reset to zero.	Spring missing from wheel pawl or broken pawl.	Replace defective wheel. See Section 6.
Input shaft binds when turned by hand.	Bent transfer pinion shaft (Figure 15).	Replace transfer pinion shaft.
Pin shears on meter or drive coupling.	Groove pin not seated flush on drive pinion. Bits of ticket in the gearing.	Seat the groove pin flush with the pinion. Clean out ticket bits from gears.
Weak or unclear print image.	Bits of torn tickets are interfering with wheel figures.	Clean dirt out of wheels and figures. See Section 4.
Print on ticket not legible.	1. Worn printing arm cushion (Figure 11). 2. Weak printing arm spring (Figure 12). 3. Bent rebound plate that does not give proper spring. 4. Weak rebound plate spring. 5. Old tickets; carbon hardened.	1. Replace printing arm cushion. 2. Replace printing arm spring. 3. Replace rebound plate. 4. Replace rebound plate spring. 5. Replace with fresh supply of tickets.
Prints zeros after delivery or for each imprint.	Out of time.	Retime the unit. See Section 6.
Double stamping or ghosting.	Weak rebound plate spring.	Replace rebound plate spring.
Print out of position.	Mispositioned ticket.	Adjust ticket tray guides and stop. See Paragraph C.

D. SALES NUMBER ADVANCING MECHANISM INSPECTION.

1. Sales number advancing mechanism, Figure 17, is tripped when printing occurs. The movement of the sale advance wheel starts immediately with rotation of the input shaft and completes transfer within $\frac{1}{4}$ of a revolution. If the sales number on the right-hand wheel does not align properly with the other wheel, it must be adjusted.
2. To align the wheel, position the tail of the clutch spring in different slots of the transfer disc until properly adjusted.

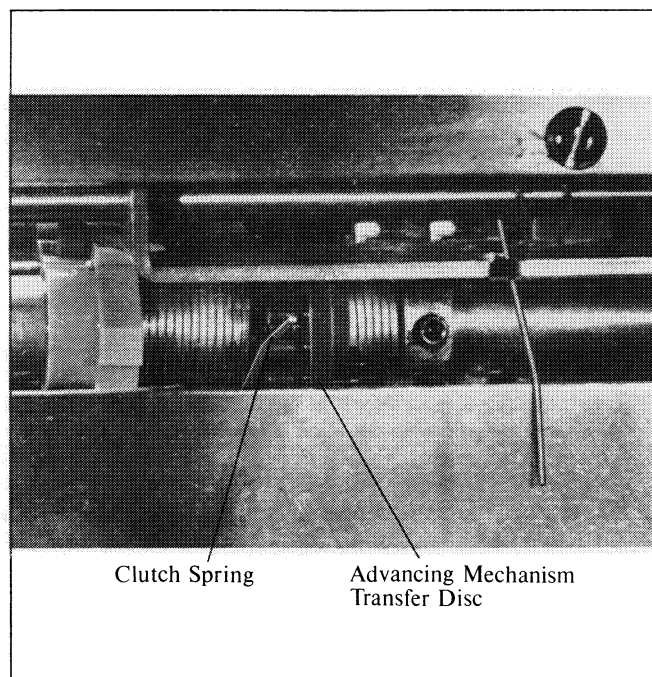

Figure 17. Adjusting Sales Number Advancing Mechanism

Table 2. Troubleshooting For Accumulative Meter Printer

TROUBLE	POSSIBLE CAUSE	CORRECTION
Printing knob turns hard.	Burrs on reset gears or teeth are damaged (Figure 13).	Check reset gear group. Replace defective gears.
Printing knob binds.	Bent ticket tray actuating pin (Figure 14).	Straighten or replace the tray.
Printing knob fails to stop after making one complete turn.	One-turn stop pawl may be bent. Spring may be missing (Figure 12).	Straighten pawl or replace spring.
Printing knob binds at one area of reset cycle.	Printing arm cam groove pin not seated properly (Figure 11).	Seat the groove pin properly.
Reset shaft jams.	Reset gears may be out of time.	Check reset gears and time as required. See Section 6.
Right-hand numbers not aligned with middle numbers	Right-hand wheel inching mechanism not adjusted properly (Figure 18).	Adjust inching mechanism. See Paragraph E.
Input shaft binds when turned by hand.	Bent transfer pinion shaft (Figure 15).	Replace transfer pinion shaft.
Pin shears on meter or drive coupling.	Groove pin not seated flush on drive pinion. Bits of ticket in the gearing.	Seat the groove pin flush with the pinion. Clean out ticket bits from gears.
Weak or unclear print image.	Bits of torn tickets are interfering with wheel figures.	Clean dirt out of wheels and figures. See Section 4.
Print on ticket not legible.	<ol style="list-style-type: none"> 1. Worn printing arm cushion (Figure 11). 2. Weak printing arm spring (Figure 12). 3. Bent rebound plate that does not give proper spring. 4. Weak rebound plate spring. 5. Old tickets; carbon hardened 	<ol style="list-style-type: none"> 1. Replace printing arm cushion. 2. Replace printing arm spring. 3. Replace rebound plate. 4. Replace rebound plate spring. 5. Replace with fresh supply of tickets.
Double stamping or ghosting.	Weak rebound plate spring.	Replace rebound plate spring.
Print out of position.	Mispositioned ticket.	Adjust ticket tray guides and stop. See Paragraph C.



E. RIGHT-HAND WHEEL INCHING MECHANISM ADJUSTMENT.

1. Adjustment of the inching of the printer's right-hand wheel is accomplished by turning the adjusting set screw, Figure 18. Turning screw clockwise, the inching occurs at a higher number and counterclockwise at lower inching numbers.
2. With reference to the printer only, inching should take place between 0.3 and 0.4 above any previous number.

SECTION 6. REPAIR AND REPLACEMENT

A. TICKET TRAY REMOVAL (Figure 19).

1. Turn knob to print position (print hammer down) and remove printing arm spring.
2. Turn knob to stop position (seal lever up).
3. Flip printing arm to rear and remove three groove pins from printing arm shaft.
4. Pull out printing shaft from left side.
5. Remove pin from printing arm cam and reset drive gear.
6. Remove E-ring from center knob shaft. Pull shaft out from right side until flush with frame. Leave gears engaged.
7. Remove all tray rod clips and tray support rods.
8. Lift tray up while tilting left side up.

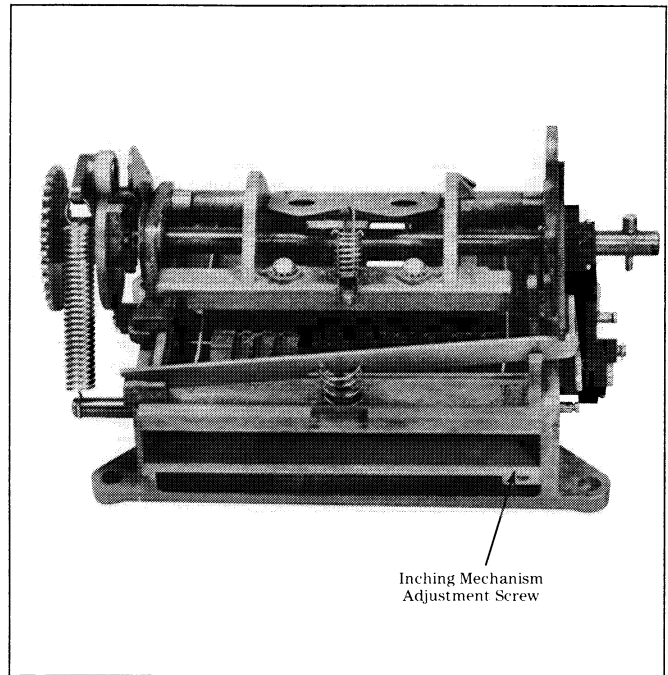

Figure 18. Right-Hand Wheel Inching Mechanism Adjustment Screw

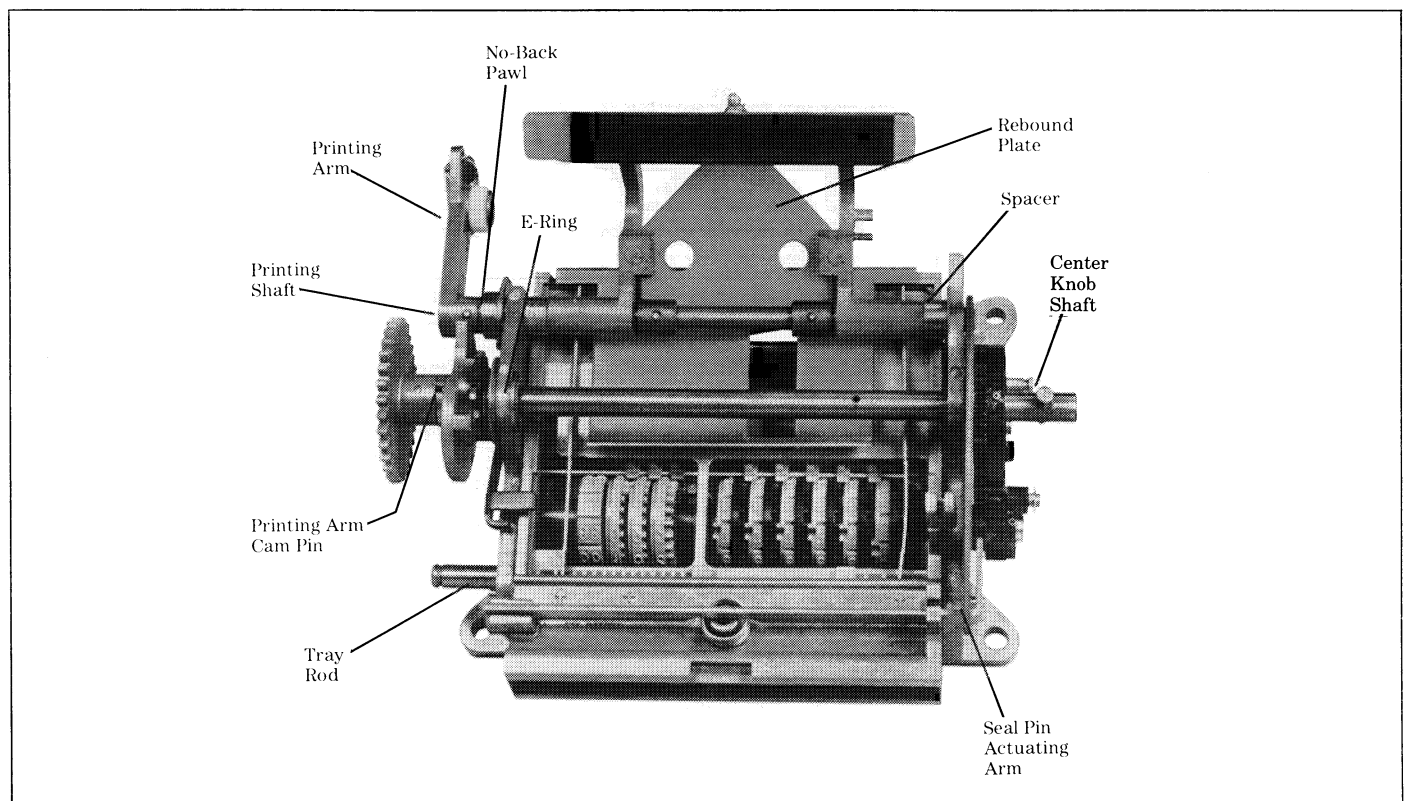

Figure 19. Ticket Tray Parts Identification



B. WHEEL REMOVAL.

1. Remove ticket tray (See Paragraph A).
2. Remove retaining ring and washer from wheel shaft (left side).
3. Remove wheel aligning spring from wheel shaft (right side) (See Figure 3).
4. Pull wheel shaft out from right side.

Note: The shaft must be pulled out slowly so wheels, bushing and washers may be removed individually without damage to the printing wheels.

C. WHEEL INSTALLATION.

For Zero Start Printers

1. Start wheel shaft through frame (right side) and install two washers inside next to frame.

Note: When starting shaft through frame, keep spline facing out to front.

2. Place the right wheel and ratchet assembly on the shaft.

Note: Wheel should be installed with zero in up position. This can be checked by moving stamping pad down over wheel to see that figure is centered in pad.

3. Move transfer pinion over to right and mesh with right-hand wheel.
4. Move shaft to left and install next wheel on shaft, then place next transfer pinion into position.
5. Continue to place wheels and transfer pinions on the shaft until all quantity wheels are in place.

Note: Make certain that teeth of transfer pinions line up; that is, all short teeth must line up and all long teeth must line up.

6. After quantity wheels are in place, place washers and short spacers on shaft. The sale number wheels are then added, engaging their drive pinions. Add identifier wheels.
7. Install long spacer and check end play: 0.020 to 0.025 inches.
8. Place washer on wheel shaft (outside of frame) and install retaining E-ring.

For Accumulative Printers

9. Start wheel shaft through frame (right side) and install one washer inside next to frame.
10. Place the ratchet assembly, drive coupling and right wheel on the shaft.

Note: Wheel should be installed with zero in up position. This can be checked by moving stamping pad down over wheel to see that figure is centered in pad.

11. Move transfer pinion over to right and mesh with right-hand wheel.
12. Move shaft to left and install next wheel on shaft, then place next transfer pinion into position.
13. Continue to place wheels and transfer pinions on the shaft until all quantity wheels are in place.

Note: Make certain that teeth of transfer pinions line up; that is, all short teeth must line up and all long teeth must line up.

14. After quantity wheels are in place, place washers and short spacers on shaft. The sales number wheels are then added, engaging their drive pinions. Add identifier wheels.
15. Install long spacer and check end play: 0.020 to 0.025 inches.
16. Place washer on wheel shaft (outside of frame) and install retaining E-ring.

D. TICKET TRAY INSTALLATION (Figure 19).

1. Place tray inside, frame tilting right side down to allow tray stud to pass through opening in frame (right side). Be sure that tray stud enters internal groove of actuating cam.
2. Install tray support rods. Double groove must be at right in front position and at left in rear position.
3. Push center knob shaft in, keeping two washers between retaining ring groove and frame. Check timing of gears (see Paragraph E, step 9).
4. Install E-ring and place two washers on shaft outside the frame, small diameter washer next to frame.
5. Place and pin printing cam on shaft, keeping cam cliff in upper rear position with head of printing knob stud up. Assemble and pin reset drive gear, timing mark down.
6. Place no-back pawl and two washers on printing shaft and start shaft through frame (left side), placing spacer, platten, rebound plate, and spacer between frames.
7. Start shaft through hole in right side. Assemble piercing arm and spring to ticket tray. Assemble seal pin actuating arm, which should still be in place, over piercing arm and onto printing shaft.
8. Pin rebound plate and spacer to printing shaft.
9. Adjust the position of the print on the ticket. See Ticket Position Adjustment, Section 5.

E. RESET GEARS REPLACEMENT AND TIMING OF PRINTER (See Figure 3 for parts identification.)

1. Remove E-ring and washer and spring from reset shaft gear.
2. Remove E-ring and washer from reset gear.
3. Remove roll pin from reset shaft gear.
4. Remove reset gear.
5. Remove center knob shaft per Section 6, Paragraph A, steps 5 and 6, and pull shaft from frame.
6. Remove reset drive gear.
7. Assemble new reset drive gear onto shaft and start shaft through hole in right side. Assemble piercing arm and spring to ticket tray. Assemble seal pin actuating arm, which should still be in place, over piercing arm and onto printing shaft.

Note: Timing mark on gear must be down in relation to the head of the printing knob stud.

8. Install center knob shaft per Section 6, Paragraph D, steps 3, 4 and 5.
9. Hold tray in rear position and install reset gear on stud.

Note: Timing mark on small reset drive gear must mesh between the two timing marks on the large reset gear.



Installation, Operation and Service Instructions Series 7888 Meter Printer

10. To check internal cam engagement with tray stud, rotate reset gear two revolutions, noting tray movement.
11. Install washer and E-ring on reset gear stud.
12. With timing marks aligned, install reset shaft gear on shaft and secure with roll pin.

Note: Roll pin must be flush with gear teeth.

13. Install wheel aligning spring, washer and E-ring.

SECTION 7. INSTALLATION INSTRUCTIONS FOR KITS 312020-357, -423, -675, AND -893

A. INTRODUCTION. Each kit contains all parts necessary for installation of a Series 7888 Ticket Printer on a Series 7887 Meter Register.

B. PARTS LIST. Check the kit contents against the parts list to ensure that all parts are included.

PART NO.	DESCRIPTION	QTY.
44602-005	Seal	1
11853-285	Seal Wire	1
74800-181	Washer, Knob (Steel)	1
74800-125	Washer, Knob (Rubber)	1
324757-001	Knob, Printer Reset	1
502300-108	Screw, #8-36 x 2 1/4 Inch Flathead	1
502300-109	Screw, #8-36 x 1 3/4 Inch Flathead (For -893 only)	1
503641-005	Screw, 1/4-28 x 3/4 Inch Hex Socket Head Cap	4
510003-006	Lockwasher, 1/4 Inch	4
325894-001	Plug, Reset Shaft Security	1
324718-001	Cover, Reset Knob Hole	1
502721-001	Screw, #10-24 x 3/8 Inch Round Head	3
510002-001	Lockwasher, #10	3
76124-005	Gasket, Reset Knob Hole	1
403071-420	Gear, Large Idler	1
511800-106	Retaining Ring	1
885005-789	Washer, 0.010 Inch Thick	4
885005-791	Washer, 0.005 Inch Thick	4
885005-937	Washer, Spring	1
251322	Manual, Instruction	1
328741-001	Shaft Extension (Right Side)	1
328741-002	Shaft Extension (Left Side) (For -893 only)	1

C. INSTALLATION INSTRUCTIONS.

1. Remove the four corner bolts with lockwashers from the bottom of the meter register. Remove the cover.
2. Unscrew the meter register reset knob.
3. Remove the meter register reset knob flange mounting screws and flange.
4. Remove the three hex screws that secure the meter register frame to the bottom of the case.
5. Remove the meter register frame from the case.
6. Install the reset knob hole cover and gasket with three 10-24 x 3/8 inch roundhead screws and lockwashers.
7. Manually reset the meter register character wheels to zero and set the unit aside.
8. Temporarily set the ticket printer knob and shaft extension on the printer center knob shaft. Turn the knob until the ticket tray is in the outward position and the internal stop prevents the knob from being turned further. Remove the knob and shaft extension.

Note: When installing ticket printer on meter register, ensure that meter register gear is positioned with timing mark (o) pointing straight up (Figure 6).

9. Install the ticket printer on the meter register with four 1/4 inch lockwashers and four 1/4-28 x 3/4 inch hex socket head cap screws. Loosen the printer bevel gear set screw and adjust for proper backlash between the printer bevel gear and the meter register drive gear as necessary (Figure 20).

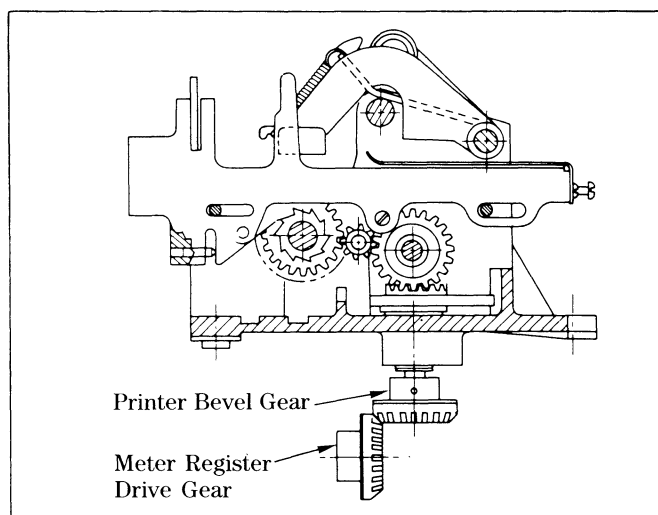

Figure 20. Ticket Printer/Meter Register Backlash Adjustment.

10.
 - a. Install a 0.005 inch washer on the meter register idler gear shaft.
 - b. Install the large idler gear on the shaft with the ribs facing in. Ensure that the idler gear timing mark is aligned with the ticket printer timing mark (Figure 6).
 - c. Install a 0.005 inch washer on the shaft.
 - d. Install the spring washer on the shaft.
 - e. Install the retaining ring and 0.005 or 0.010 inch washers as necessary to ensure that there is 0.020 inch \pm 0.005 inch between the idler gear and the retaining ring.
11. Install the plastic security cap on the end of the meter register reset idler gear shaft.
12. Install the meter register/ticket printer assembly in the case and secure with the three hex screws removed earlier.
13. Install the ticket printer cover with the four corner bolts removed earlier.



14. Install the large steel washer, then the rubber washer on the slotted end of the shaft extension.
 15. Insert shaft extension with washers thru hole in cover and engage the end of knob shaft.
 16. Position reset knob with arrow pointing up, approximately vertical, on spline of shaft extension and secure to printer with the 2¼ inch flat-head screw for right-hand reset or use the 1¾ inch flat-head screw for left-hand reset.
- D. OPERATIONAL CHECK.** Perform the following to ensure that the meter register/ticket printer assembly is ready for service.
1. Lift the ticket slot cover and insert a ticket as far as it will go. If the ticket will not enter the tray, turn the ticket printer knob one complete revolution until the internal stop is reached. This lifts the sealing pin and permits insertion of the ticket.
 2. Turn the ticket printer knob one complete turn (clockwise for right-hand reset or counterclockwise for left-hand reset) until the internal stop is reached, leaving the knob arrow pointing up.
 3. Simulate a delivery by manually turning the meter register driveshaft clockwise. Make sure that the character wheels advance smoothly without binding.
 4. After completing the simulated delivery, turn the ticket printer knob one complete revolution until the internal stop is reached.
 5. Withdraw the ticket and check for the following:
 - a. **Your Sale No.** must be one digit higher than **Previous Sale No.**
 - b. **Gallon Reading — Finish** minus **Gallon Reading —** must equal the simulated delivery shown on the meter register.

SECTION 8. WARRANTY AND CONDITIONS

A. WARRANTY. We warrant that our products shall be free from defects in material and workmanship for a period of one year from the date of shipment thereof or the product's total rated life, whichever first occurs. Within the warranty period we shall repair or replace such products which are returned to us with shipping charges prepaid and which are determined by us to be defective. This warranty will not apply to any produce which has been subjected to misuse, negligence, or accident; or misapplied; or used in violation of product manuals, instructions, or warnings; or modified or repaired by unauthorized persons; or improperly installed.

B. INSPECTION. You shall inspect the product promptly after receipt and shall notify us at our Altoona office, in writing, of any claims, including claims of breach of warranty, within thirty days after you discover or should have discovered the facts upon which the claim is based. Your failure to give written notice of a claim within the time period shall be deemed to be a waiver of such claim.

C. LIMITATION OF REMEDY AND WARRANTY. The provisions of Paragraph 1 are our sole obligation and exclude all other remedies or warranties, express or implied, including warranties of **MERCHANTABILITY** and **FITNESS FOR A PARTICULAR PURPOSE**, whether or not purposes or specifications are described herein. We further disclaim any responsibility whatsoever to you or to any other person for injury to person or damage to or loss of property or value

caused by any product which has been subjected to misuse, negligence, or accident; or misapplied; or used in violation of product manuals, instructions, or warnings; or modified or repaired by unauthorized persons; or improperly installed.

D. LIMITATIONS OF DAMAGES. Under no circumstances shall we be liable for any incidental, cosequential or special damages, losses or expences arising from this contract or its performance or in connection with the use of, or inability to use, our product for any puporse whatsoever.

E. LIMITATION OF ACTIONS. No action regardless of form arising out of this contract may be commenced more than one year after the cause of action has accrued, except an action for nonpayment.

F. COLLATERAL PROMISES. There are no representations, warranties, or condtions express or implied, statutory or otherwise except those herein contained, and no agreements or waivers collateral hereto shall be binding on either party unless in writing and signed by you and accepted by us at our Altoona office.

G. INTERPRETATION. Rights and liabilities arising out of any contract with us shall be determined under the Uniform Commercial Code as enacted in Connecticut.



6th Avenue at Burns Crossing, P.O. Box 1673, Altoona, PA 16603-1673 Phone (814) 695-4476, or (800) 873-3313, Fax (814) 695-7605, or (800) 234-5350

BRAZIL: Sao Paulo • CANADA: Mississauga, Ontario • ENGLAND: Richmond Surrey • FRANCE: Aulnay-Sous-Bois • GERMANY: Aldingen • SINGAPORE: Singapore

251322 Rev.B 12595 Replaces 11622