



# CONTENTS

Scope of This Manual . . . . .	3
Unpacking and Inspection . . . . .	3
Safety . . . . .	3
Terminology and Symbols . . . . .	3
Considerations . . . . .	3
Introduction. . . . .	4
Operating the Monitor . . . . .	5
Buttons . . . . .	5
Modes. . . . .	5
Programming . . . . .	6
Programming Mode. . . . .	6
Return to Run Mode. . . . .	9
Run Mode . . . . .	9
Additional Scaling Parameters . . . . .	9
Flow 4 mA Setting . . . . .	10
Flow 20 mA Setting . . . . .	10
4...20 mA Calibration . . . . .	10
4...20 mA Test . . . . .	10
Battery Replacement . . . . .	10
Additional Input Options . . . . .	11
Additional Scaling Information. . . . .	12
Pulse Output Signals for Linear Processes . . . . .	12
Pulse Output Signals for Non-linear Processes . . . . .	13
Default K-factor Values . . . . .	13
Troubleshooting Guide. . . . .	14
Part Number Information . . . . .	14
Specifications. . . . .	15
Mounting Options and Dimensions. . . . .	16
Meter Mount . . . . .	16
Remote Mount . . . . .	16
Swivel Mount . . . . .	17
Replacement Parts. . . . .	18
Installation Drawing. . . . .	19

## SCOPE OF THIS MANUAL

This manual is intended to help you get the B2800 flow monitor up and running quickly.

### IMPORTANT

*Read this manual carefully before attempting any installation or operation. Keep the manual accessible for future reference.*

## UNPACKING AND INSPECTION

Upon opening the shipping container, visually inspect the product and applicable accessories for any physical damage such as scratches, loose or broken parts, or any other sign of damage that may have occurred during shipment.

**NOTE:** If damage is found, request an inspection by the carrier's agent within 48 hours of delivery and file a claim with the carrier. A claim for equipment damage in transit is the sole responsibility of the purchaser.

## SAFETY

### Terminology and Symbols



Indicates a hazardous situation, which, if not avoided, is estimated to be capable of causing death or serious personal injury.



Indicates a hazardous situation, which, if not avoided, could result in severe personal injury or death.



Indicates a hazardous situation, which, if not avoided, is estimated to be capable of causing minor or moderate personal injury or damage to property.

### Considerations

The installation of the B2800 monitor must comply with all applicable federal, state, and local rules, regulations, and codes.



**EXPLOSION HAZARD - SUBSTITUTION OF COMPONENTS MAY IMPAIR SUITABILITY FOR CLASS I, DIVISION 2.**



**RISQUE D'EXPLOSION - LA SUBSTITUTION DE COMPOSANTS PEUT RENDRE CEMATÉRIEL INACCEPTABLE POUR LES EMPLACEMENTS DE CLASSE I, DIVISION 2.**



**DO NOT CONNECT OR DISCONNECT EITHER POWER OR OUTPUTS UNLESS THE AREA IS KNOWN TO BE NON-HAZARDOUS.**



**RISQUE D'EXPLOSION. NE PAS DÉBRANCHER TANT QUE LE CIRCUIT EST SOUSTENSION, À MOINS QU'LL NE S'AGISSE D'UN EMPLACEMENT NON DANGEREUX.**

### IMPORTANT

*Not following instructions properly may impair safety of equipment and/or personnel.*

## INTRODUCTION

The B2800 flow monitor is a state-of-the-art digital signal processing flow monitor, designed to provide exceptional flexibility at a very affordable price. Though designed for use with Blancett flow meters, this display can be used with almost any flow meter producing a low amplitude AC output or contact closure signal.

This flow monitor is capable of accepting a low level frequency input for calculating flow rate and total. These calculations can then be displayed in the specified units of measurement. All B2800 flow monitors are pre-programmed at the factory, if ordered with a Blancett flow meter. If required, however, the monitor can easily be reconfigured in the field.

The monitor's large 8-digit by 0.75 in. (19.05 mm) numeric liquid crystal display makes extended range viewing practical. The second 8-digit by 0.38 in. (9.65 mm) alphanumeric display provides for selectable units viewing in *RUN* mode and prompts for variables in program mode. You can display rate or total, or alternate between rate and total.

# OPERATING THE MONITOR

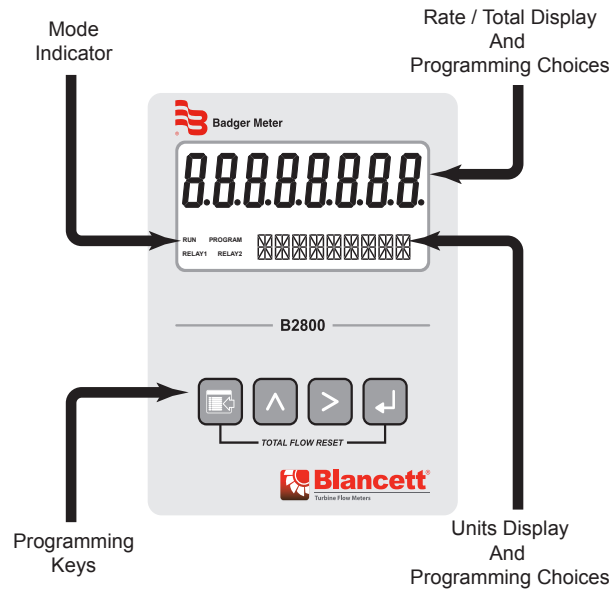

Figure 1: B2800 flow monitor

## Buttons

	<b>MENU</b>	Enters and exits <i>PROGRAM</i> mode
	<b>UP</b>	Scrolls forward through the parameter options, increments numeric variables and scrolls backward through parameters
	<b>RIGHT</b>	Scrolls backward through the parameter options, moves the active digit to the right and scrolls forward through parameters
	<b>ENTER</b>	Saves programming information, advances to the next programming parameter, and used in the reset process

## Modes

<b>RUN</b>	Normal operating mode
<b>PROGRAM</b>	Used to program parameters in the display

If your monitor was ordered with a Blancett flow meter, the two components ship from the factory calibrated as a set. If the monitor is a replacement, the turbine's K-factor has changed or the monitor is being used with some other pulse generating device, the monitor must be programmed.

# PROGRAMMING

Each turbine flow meter is shipped with either a K-factor value or frequency data. If frequency data is provided, the data must be converted to a K-factor before programming the monitor. K-factor information, when supplied, can usually be found on the neck of the flow meter or stamped on the flow meter body. The K-factor represents the number of pulses per unit of volume. The K-factor will be needed to program the monitor readout.

## Programming Mode

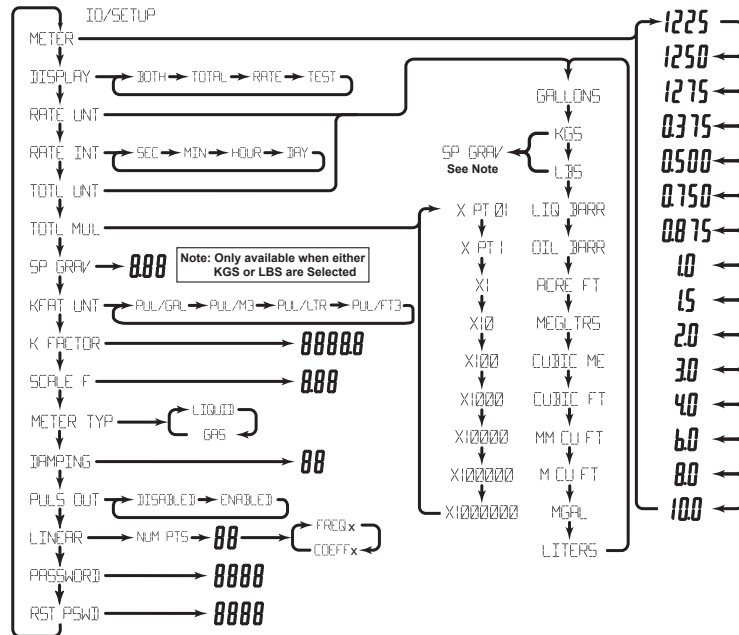

Figure 2: Advanced programming menu

### Enter Programming Mode

Press **MENU** to enter the programming mode. The mode indicator changes from *RUN* to *PROGRAM*.

**NOTE:** If any input value exceeds the meter’s capabilities for that particular parameter, the *LIMIT* indicator flashes, indicating an invalid entry. Press **ENTER** to return to the parameter’s entry screen to reenter the value.

### Select Meter Size

At the *METER* prompt, press **ENTER**. The current meter size flashes. If the current setting is correct, press **ENTER** to advance to the next parameter. To change the current setting, press **UP** or **RIGHT** to scroll to the bore size of your meter. Press **ENTER** to save and advance to the *DISPLAY* parameter.

**NOTE:** The meter connection size and the bore size are different. For example, many of the one inch NPT turbines have bore sizes that range from 3/8...1 in. (9.53...25.4 mm). Use the correct bore size so the meter will report correct flows and totals.

### Select Display Function

The monitor can display *RATE* or *TOTAL* or alternate between *BOTH* rate and total. At the *DISPLAY* prompt, press **ENTER**. The monitor shows the current display mode. To change to an alternate display mode, press **UP** or **RIGHT** to scroll to the correct display mode. Press **ENTER** to save and advance to the *RATE UNIT* parameter.

### Select Units of Measure

At the *RATE UNIT* prompt, press **ENTER**. The monitor shows the current rate unit. If the current selection is correct, press **ENTER** to advance to the next parameter. To change to an alternate unit, press **UP** or **RIGHT** to scroll to the correct rate unit. Press **ENTER** to save and advance to the *RATE INT* parameter.

### Select Rate (Time) Interval

At the *RATE INT* prompt, press **ENTER**. The monitor shows the current time interval. If the current selection is correct, press **ENTER** to advance to the next parameter. To change to an alternate time interval, press **UP** or **RIGHT** to scroll to the correct time interval. Press **ENTER** to save and advance to the *TOTL UNT* parameter.

**NOTE:** If flow rate is the only measurement of interest, press **RIGHT** to advance to the *KFAC UNT* to complete the programming process.

### Select Units of Measure

At the *TOTAL UNT* prompt, press **ENTER**. The monitor shows the current total units. If the current selection is correct, press **ENTER** to advance to the next parameter. To change to an alternate unit, press **UP** or **RIGHT** to scroll to the correct totalization unit. Press **ENTER** to save and advance to the *TOTL MUL* parameter.

**NOTE:** This unit of measure does not have to reflect the rate unit you have previously chosen.  
Example: Rate Units = Gallons, Total Units = Barrels

### Select Total's Display Multiplier

This parameter displays the accumulated flow total in multiples of 10. For example, if the optimum totalization unit is 1000 gallons, the unit total display increments by one digit for every 1000 gallons monitored. In *RUN* mode, at 1000 gallons the total monitor reads 1, at 3000 gallons, the total display reads 3. This feature eliminates having to look at a total, count the digits, and mentally insert commas for each 1000 multiple.

At the *TOTL MUL* prompt, press **ENTER**. The monitor shows the current total multiplier. If the current selection is correct, press **ENTER** to advance to the next parameter. To change to an alternate multiplier, press **UP** or **RIGHT** to scroll to the correct multiplier unit. Press **ENTER** to save and advance to the *KFAC UNT* parameter.

**NOTE:** If pounds or kilograms were chosen as the *RATE UNT* or *TOTL UNT*, the monitor advances to the *SP GRAV* parameter.

#### *Specific Gravity*

At the *SP GRAV* parameter, press **ENTER**. The first digit of the current specific gravity flashes. If the current setting is correct, press **ENTER** to advance to the next parameter. To change the current setting, press **RIGHT** to move to the correct digit. Press **UP** to increment the digit. Repeat for all digits. Press **ENTER** to save and advance to the *KFAC UNT* parameter.

### Enter Meter's K-Factor Unit

**NOTE:** The K-factor supplied with the meter, or calculated from calibration data, is needed to complete this step.

At the *KFAC UNT* prompt, press **ENTER**. The display shows the current K-factor unit. If the current selection is correct, press **ENTER** to advance to the next parameter. To change the K-factor, press **UP** or **RIGHT** to scroll to the correct K-factor. Press **ENTER** to save and advance to the *SCALE F* parameter.

**NOTE:** For meters calibrated in gallons, use *PUL/GAL*; for meters calibrated in cubic meters, use *PUL/M3* or any other unit option.

### Scale Factor

The scale factor is used to force a global change to all variables. For example, under operating conditions the display is reading a consistent three percent below the expected values at all flow rates. Rather than changing all parameters individually, the scale factor is used to compensate for the three percent offset. Set the scale factor to 1.03 to correct the readings. The range of scale factors is 0.5...1.5. The default scale factor is 1.0.

At the *SCALE F* prompt, press **ENTER**. The first digit of the current scale factor flashes. If the current selection is correct, press **ENTER** to advance to the next parameter. To change to an alternate scale factor, press **UP** to increment the display digit until it matches the first digit of the new scale factor. Press **RIGHT** to advance to the next digit. Repeat for all digits. Press **ENTER** to save and advance to the *METERTYP* parameter.

## Meter Type

At the *METERTYP* prompt, press **ENTER**. The current meter type displays. If the current selection is correct, press **ENTER** to advance to the next parameter. To change the type, press **UP** or **RIGHT**. Press **ENTER** to save and advance to the next parameter. If *GAS* is selected, the operating pressure (psig) and operating temperature (° F) must be entered. If *LIQUID* is selected, the monitor advances to the *DAMPING* parameter.

**NOTE:** The 4...20 mA zero and span values are not factory set.

### Operating Pressure

At the *OP PRES* prompt, press **ENTER**. The first digit of the current setting flashes. If the current setting is correct, press **ENTER** to advance to the next parameter. To change the current setting, press **RIGHT** to move to the correct digit. Press **UP** to increment the digit until it matches the new operating pressure. Repeat for all digits. Press **ENTER** to save and advance to the *OP TEMP* parameter.

### Operating Temperature

At the *OP TEMP* prompt, press **ENTER**. The first digit of the current setting flashes. If the current setting is correct, press **ENTER** to advance to the next parameter. To change the current setting, press **RIGHT** to move to the correct digit. Press **UP** to increment the digit until it reaches the new operating temperature. Repeat for all digits. Press **ENTER** to save and advance to the *DAMPING* parameter.

## Damping Factor

The damping factor is increased to enhance the stability of the flow readings, and decreased to allow the flow meter to react faster to changing values of flow. This parameter can be any value 0...99 with 0 being the default.

At the *DAMPING* prompt, press **ENTER**. The first digit of the current damping setting flashes. If the current selection is correct, press **ENTER** to advance to the next parameter. To change the damping factor, press **UP** to increment the digit. Press **RIGHT** to move to the next digit. After all digits are entered, press **ENTER** to save and advance to the *PULS OUT* parameter.

## Totalizer Pulse Output

The pulse output parameter can be either enabled or disabled. When enabled, this output generates a 20 mS duration pulse for every time the least significant digit of the totalizer increments. The amplitude of the pulse is dependent on the voltage level of the supply connected to the pulse output and is limited to a maximum 30V DC.

## Linearization

Linearization enhances the accuracy of the display. The linearization accepts a maximum of ten points and requires additional calibration data from the meter being used with the monitor. Typically, calibration information can be obtained in three, five and ten points from the flow meter's manufacturer. If linearization is not needed, press **RIGHT** to advance to the next parameter. To complete linearization, press **ENTER** at the *LINEAR* prompt. The meter advances to the *NUM PTS* parameter.

### Number of Points

If the number of points is set to 0, linearization is disabled. Press **ENTER**. The most significant digit of the number of points entry begins to flash. The first number can be a 1 or a 0 only. Press **UP** to increment the first digit. Press **RIGHT** to move to the least significant digit. When both digits have been entered, press **ENTER** to save and advance to the *FREQ 1* parameter.

### Frequency

At the *FREQ 1* prompt, press **ENTER**. The first digit of the first linear point's frequency input flashes. If the first frequency is correct, press **ENTER** to advance to the next parameter. To change the frequency, press **UP** to increment the digit. Press **RIGHT** to move to the next digit. After all digits are entered, press **ENTER** to save and advance to the *COEFF 1* parameter.

### Coefficient

The coefficient is the value applied to the nominal K-factor to correct it to the exact K-factor for that point. The coefficient is calculated by dividing the actual K-factor for that point by the average K-factor for the flow meter.

$$\text{Coefficient} = \frac{\text{Actual K-Factor}}{\text{Average K-Factor}}$$

At the *COEFF* prompt, press **ENTER**. The first digit of the coefficient flashes. If the first coefficient is correct, press **ENTER** to advance to the next parameter. To change the frequency, press **UP** to increment the digit. Press **RIGHT** to move to the next digit. Repeat for all digits. After all digits are entered, press **ENTER** to save and advance to the next set of linear points. Continue entering pairs of frequency and coefficient points until all data has been entered. Press **MENU** twice at the *NUM PTS* prompt to exit to the *LINEAR* prompt. Press **RIGHT** to advance to the *PASSWORD* parameter.

---



### Password

The password setting restricts access to *PROGRAM* mode. Initially, the password is set to all zeros and any user can modify the parameter settings. To change the password, press **ENTER** at the *PASSWORD* prompt. The first digit flashes. Press **UP** to increment the digit and **RIGHT** to advance to the next digit. After entering all digits, press **ENTER** to store the password and advance to *RST PSWD*. The new password is now required to enter *PROGRAM* mode. With this password set, any user is able to reset the stored totals on the monitor.

**NOTE:** This password will allow the operator to manually reset totals.

### Reset Password

The reset password parameter restricts resetting the totals on the monitor. The *PASSWORD* must also be set to restrict the total reset. Initially, the password is set to all zeros and any user can reset the stored totals on the monitor. To change the password, press **ENTER** at the *RST PSWD* prompt. The first digit flashes. Press **UP** to increment the digit and **RIGHT** to advance to the next digit. After entering all digits, press **ENTER** to store the password and return to the *METER* parameter. The reset password is now required to reset the totals on the monitor.

**NOTE:** Entering a password in the *PASSWORD* screen and leaving the default password in the *RST PSWD* screen allows for total resets (not requiring a password), but restricts programming modification.

### Return to Run Mode

After entering all parameters, press **MENU** to return to *RUN* mode.

### Run Mode

#### Reset Total

To reset the monitor's total display, in *RUN* mode, press **MENU** and **ENTER** simultaneously until *TOTAL RST* starts to flash. The display returns to the *RUN* mode at the conclusion of the reset procedure.

#### Store Total

The current total can be manually stored in the monitor's flash memory. This procedure may be needed prior to changing the settings or replacing the battery. Press and hold **ENTER** for two seconds. The display flashes *TOTALSVD* and then returns to *RUN* mode.

#### Automatic Store Total

The monitor is equipped with a store total feature that works automatically, saving the current total to flash memory. The frequency of saves depends on the power supply option chosen.

- Battery Powered: Once per hour and just before a low battery condition turns the unit off.
- Loop Powered: Once every ten minutes.

## ADDITIONAL SCALING PARAMETERS

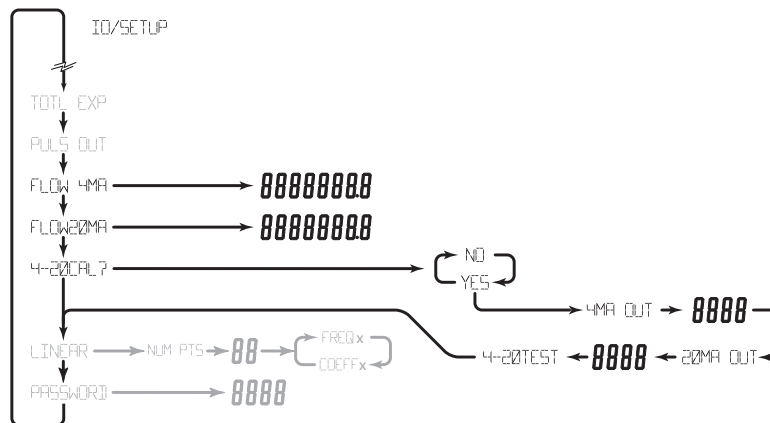

Figure 3: 4...20 mA programming menu

**NOTE:** The programming instructions in this section are only available for loop powered units. Battery powered units do not include these programming parameters.

## Flow 4 mA Setting

Zero is the default flow rate at the 4 mA setting. If the current selection is correct, press **ENTER** to advance to the *Flow 20 mA* parameter. To change the setting, press **UP** to increment the flashing digit and press **RIGHT** to move to the next digit. Press **ENTER** to save and advance to the *Flow 20 mA* parameter.

## Flow 20 mA Setting

The turbine meter's maximum flow rate is the default value for the 20 mA setting. If the current selection is correct, press **ENTER** to advance to the *4...20 mA Calibration* parameter. To change the setting, press **UP** to increment the flashing digit and press **RIGHT** to move to the next digit. Press **ENTER** to save and advance to the *4...20 mA Calibration* parameter.

## 4...20 mA Calibration

The *4...20 mA Calibration* parameter is the fine adjustment of the 4...20 mA output. The 4 mA setting is typically between 35...50. To set the 4 mA value, connect an ammeter in series with the loop power supply. At the *4MA OUT* prompt, press **UP** to increment and **RIGHT** to decrement the 4 mA value until a steady 4 mA reading is reached on the ammeter. Press **ENTER** to lock in this value and advance to *20MA OUT*. The 20 mA adjustment is performed using the same procedure as the 4 mA adjustment.

## 4...20 mA Test

The monitor contains a diagnostic routine that allows the simulation of mA values between 4...20 to check output tracking. At the *4-20TEST* prompt press **UP** to increment the simulated mA output or **RIGHT** to decrement the value in increments of 1 mA. The ammeter should track the simulated mA output. If a 4...20 mA test is not necessary, press **ENTER** once to escape the testing at any time.

**NOTE:** If you ordered the B2800 flow monitor with a Blancett turbine flow meter, the 4...20 mA was programmed and factory calibrated.

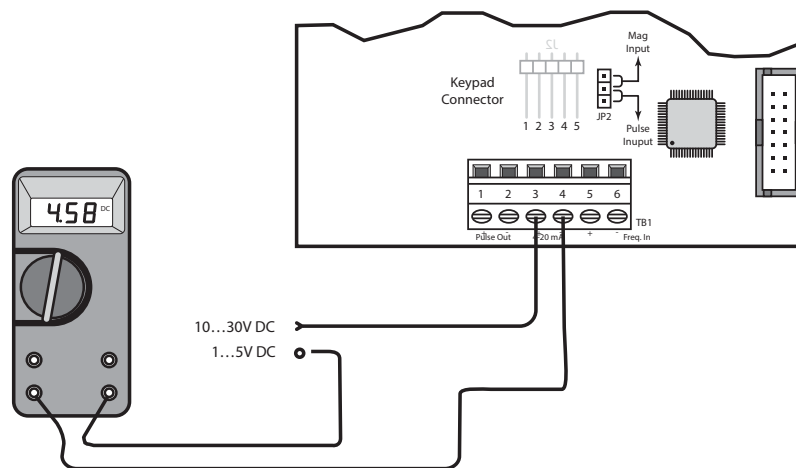

Figure 4: Typical ammeter connection

## BATTERY REPLACEMENT

Battery powered monitors use a single 1.5V, D size alkaline battery. When replacement is necessary, use a clean fresh battery to ensure continued trouble-free operation. It is recommended that the total be saved to memory before the battery is removed.

1. Unscrew the two captive screws on the front panel to gain access to the battery.
2. Replace the battery, being sure to observe the proper polarity.
3. Refasten the front panel.

# ADDITIONAL INPUT OPTIONS

The B2800 flow monitor is capable of receiving magnetic pickup input (small signal sine wave) or a contact closure input (pulse). Since most Blancett turbine flow meters use a magnetic pickup, the B2800 flow monitor is shipped configured for magnetic pickup input. To change to a contact closure input, remove JP2 from the top two pins and jumper them to the bottom two pins. See *Figure 6*.

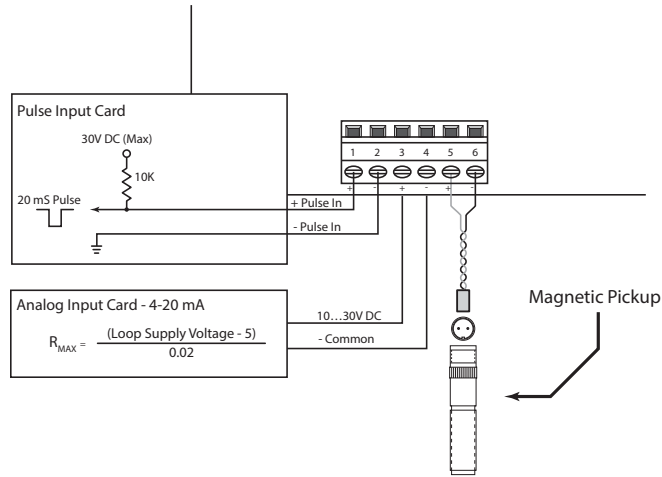

Figure 5: Wiring diagram

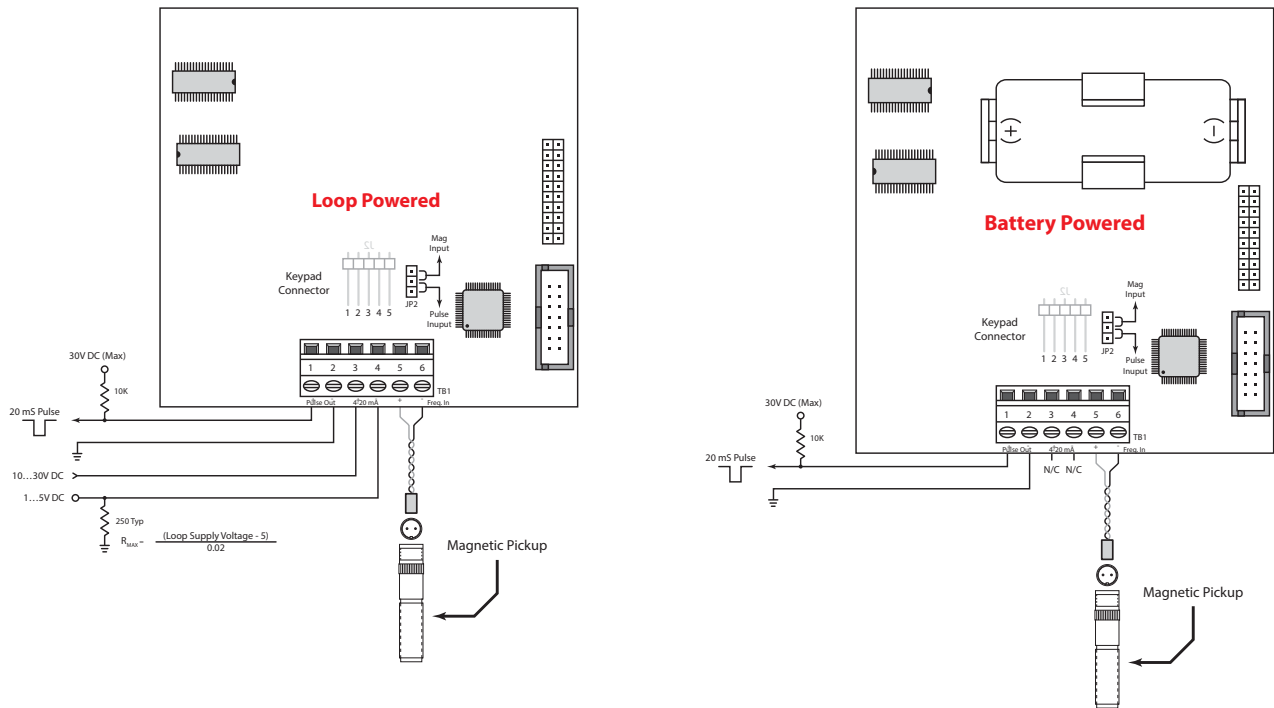

Figure 6: Circuit board layouts

## ADDITIONAL SCALING INFORMATION

This information is supplied as a general introduction to the basic concepts used to scale rate displays. The applicability of the information is dependent on the type and capabilities of the specific display/monitor used.

Flow meters producing an electronic signal are normally supplied in one of two output formats. The pulse format generates some form of alternating signal that can be raw, that is no amplification or wave shaping can be done prior to transmission to the readout. The output pulse rate is related proportionally to flow rate. Pulses can also be modified to produce higher output amplitudes or specific wave shapes.

The other output format is an analog signal. This is a continuous, variable voltage or current signal that is normally scaled to the dynamic range of the meter. Typical analog signals are 0...5V DC, 0...10V DC, and 4...20 mA. The analog signals may or may not be derived from a raw pulse signal produced by the flow meter.

Scaling for any of these input signals always requires at least two scaling points for a linear process – zero or minimum flow point and the maximum flow point. Additionally, each scaling point has two components, the actual input signal value and the desired display value at that input signal for that scaling point.

For example, a pulse output flow meter has a flow of 50 gpm at a pulse rate of 100 Hz. The actual input signal is the 100 Hz figure, but allowing the display to read 100 would be meaningless to the operator. The solution to this problem is to scale the display to read 50 (gpm) when the input is 100 Hz.

### Pulse Output Signals for Linear Processes

Pulse output signals are related to flow rate by a constant, usually referred to as the K-factor. The K-factor is reported as the number of accumulated pulses that represents a particular volume, such as gallon or liter. K-factors are indicated in pulses per unit volume or counts per unit volume. An example of a K-factor, normally supplied by the manufacturer, might be 2000 counts per gallon. The K-factor is correlated to flow through a simple mathematical relationship:

$$\text{Frequency} = \frac{\text{K-factor} \times \text{Volume per unit of time}}{60}$$

Using the previous example of 2000 counts per gallon and further assuming this meter has a maximum flow rate of 25 gpm, the formula can be arranged to calculate the input frequency required for a scaling point as follows:

$$\text{Frequency} = \frac{2000 \times 1 \text{ (gal)}}{60} = 33.333 \text{ Hz at 1 gpm}$$

Given that the meter has a maximum flow rate of 25 gpm, the maximum frequency would then be:

$$\text{Frequency} = \frac{2000 \times 25 \text{ (gal)}}{60} = 833.333 \text{ Hz at 25 gpm}$$

A programmable display requires at least two points. The first point is the zero or minimum flow and the second is normally the maximum flow rate. For the imaginary flow meter used in the example above, the scaling would be as follows:

Input Value for Scaling Point 1	=	0
Display Value for Scaling Point 1	=	0
Input Value for Scaling Point 2	=	833.33
Display Value for Scaling Point 2	=	25

## Pulse Output Signals for Non-linear Processes

Few flow meters actually behave in a linear way. There is always some uncertainty about the exact flow at a given reported input value. For many common flow measurement applications, the assumption of linear flow is adequate for the process being measured. When higher accuracy is required, a technique called linearization is often employed.

When the flow meter is being calibrated, multiple data points are obtained for the particular meter being tested. A typical five point calibration run is displayed below.

GPM (LPM)	Average Frequency	**UUT Hz Counts/GAL	UUT K (Hz × 60)/NK gpm	Error (% FS)
15.00 (59.78)	769.7	3078.59	14.90	-0.65
9.06 (34.3)	466.1	3086.75	9.03	-0.38
5.49 (20.78)	285.2	3118.64	5.52	0.65
3.32 (12.57)	171.7	3103.95	3.32	0.17
2.00 (7.57)	103.6	3101.80	2.01	0.10

\*\*UUT = Unit Under Test

If this meter produced an actual linear output, the K-factor calculation for the Unit Under Test would be exactly the same for each measurement point. Inspection of the UUT K in the example provided shows that this is not the case and indicates that this meter is not a perfectly linear device.

Many programmable displays allow for linearization and can provide a better match of the displayed flow values with the actual flow values by incorporating more measurement points. In the example, the unit would be programmed for six points, the five data points and a zero point, and use pairs of input values to accomplish the linearization.

## DEFAULT K-FACTOR VALUES

Meter Size	Default K-factor	Lower Limit	Upper Limit
3/8 in. (9.53 mm)	20,000	16,000	24,000
1/2 in. (12.7 mm)	13,000	10,400	15,600
3/4 in. (19.05 mm)	2750	2200	3300
7/8 in. (22.23 mm)	2686	2148	3223
1 in. (25.4 mm)	870.0	696.0	1044
1-1/2 in. (38.1 mm)	330.0	264.0	396.0
2 in. (50.8 mm)	52.0	41.6	62.0
3 in. (76.2 mm)	57.0	45.6	68.0
4 in. (101.6 mm)	29.0	23.2	35.0
6 in. (152.4 mm)	7.0	5.6	8.0
8 in. (203.2 mm)	3.0	2.4	4.0
10 in. (254 mm)	1.6	1.3	2.0

## TROUBLESHOOTING GUIDE

Issue	Remedy
No LCD display	<ul style="list-style-type: none"> <li>• Check battery voltage. Should be 1.5V DC. Replace if low or dead.</li> </ul>
No rate or total displayed	<ul style="list-style-type: none"> <li>• Check connection from meter pickup to display input terminals.</li> <li>• Check turbine meter rotor for debris. Rotor should spin freely.</li> <li>• Check programming of flow monitor.</li> </ul>
Flow rate display interprets reading constantly	<ul style="list-style-type: none"> <li>• This is usually an indication of external noise. Keep all AC wires separate from DC wires.</li> <li>• Check for large motors close to the meter pickup.</li> <li>• Check for radio antenna in close proximity.</li> <li>• Try disconnecting the pickup from the monitor pig tail. This should stop the noise.</li> </ul>
Flow rate indicator bounces	<ul style="list-style-type: none"> <li>• This usually indicates a weak signal. Replace pickup and/or check all connections.</li> <li>• Check K-factor.</li> </ul>

## PART NUMBER INFORMATION

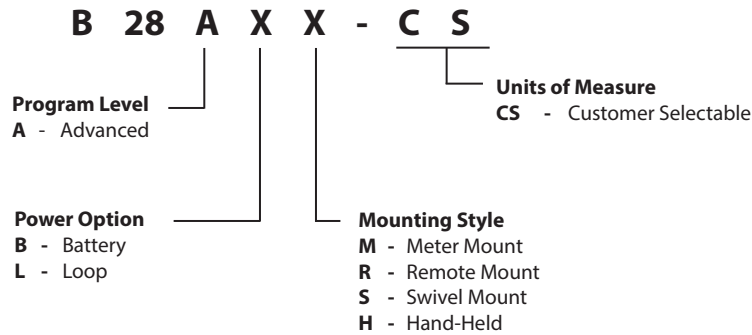

## SPECIFICATIONS

<b>Power Supply Options</b>	Battery Powered	One D size, 1.5V alkaline battery
	Loop Powered	Optional 4...20 mA loop power
<b>Power Consumption</b>	Battery Powered	Less than 1 milliwatt
	Loop Powered	25 mA (maximum)
<b>Alphanumeric Rate and Total Display</b>	Eight digit, 0.75 in. (19.05 mm) high numeric display	
	Eight character, 0.38 in. (9.65 mm) high alphanumeric display	
	Fixed or toggle modes of operation for flow rate and totalizer display	
<b>Pulse Output Signal</b>	One pulse for each increment of the least significant totalizer digit	
	Pulse Type	Opto-isolated open collector transistor
	Maximum Voltage	30V DC
	Pulse Width	(ON state) 20 mS / max pulse rate 20 Hz
	Current	(ON state) 0.9V drop @ 5.0 mA or 0.7V drop @ 0.1 mA
<b>Inputs</b>	Frequency Range	0...3500 Hz
	Trigger Sensitivity	30 mV p-p
	Over Voltage Protected	±30V DC
<b>Accuracy</b>	±0.1%	
<b>Temperature Drift</b>	50 ppm / ° C (maximum)	
<b>Analog Output (Loop Powered Version)</b>	Type	4...20 mA current loop
	Resolution	1:4000
<b>Environmental</b>	Operating Temperature	-22...158° F (-30...70° C)
	Humidity	0...90% non-condensing
<b>Enclosure Rating</b>	Meter, Remote and Swivel Mount	NEMA/UL/CSA Type 4X (IP-66)
<b>Transient Over-Voltages</b>	Category 3, in accordance with IEC664	
<b>Pollution Degree</b>	2, in accordance with IEC664	
<b>Certifications</b>	CSA	Class I, Div 1 Groups C, D; Class II, Div 1 Groups E, F, G; CSA C22.2 No.157-92, UL 913
	CE	IEC 61326-1
<b>Units of Measure</b>	US Gallons, oil barrels, liters, cubic meters, MGal, cubic ft, mliters, mcf, mmcf, acre ft, liq barrels, lbs, kgs	
	Time Intervals	Day, hour minute, second

# MOUNTING OPTIONS AND DIMENSIONS

## Meter Mount

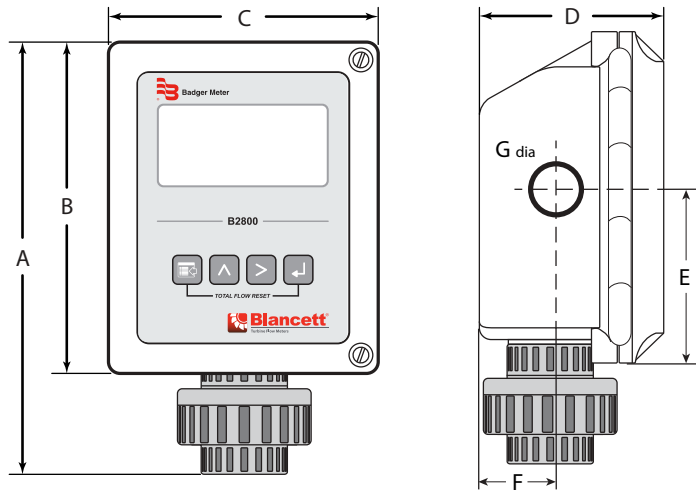

A	B	C	D	E	F	G dia
9.25 in. (235.0 mm)	7.00 in. (177.8 mm)	5.75 in. (146.0 mm)	4.00 in. (101.6 mm)	3.45 in. (87.6 mm)	1.50 in. (38.1 mm)	0.875 in. (22.2 mm)

## Remote Mount

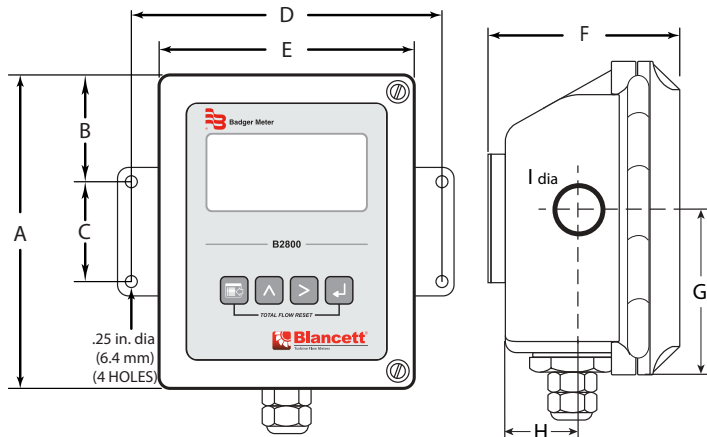

A	B	C	D	E	F	G	H	I dia
7.00 in. (177.8 mm)	2.40 in. (61.0 mm)	2.25 in. (57.2 mm)	7.00 in. (177.8 mm)	5.75 in. (146.0 mm)	4.38 in. (111.2 mm)	3.45 in. (87.6 mm)	1.50 in. (38.1 mm)	0.875 in. (22.2 mm)



**Swivel Mount**

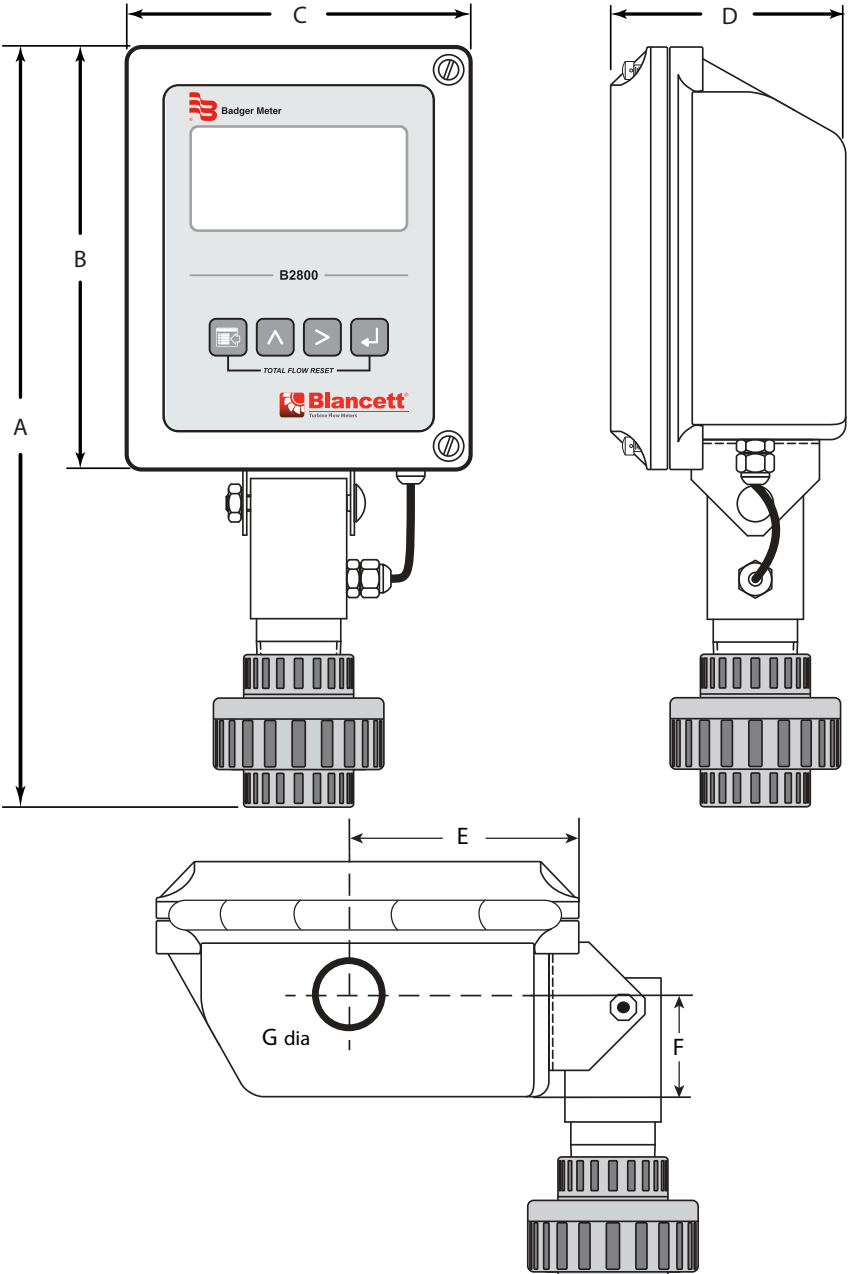

<b>A</b>	<b>B</b>	<b>C</b>	<b>D</b>	<b>E</b>	<b>F</b>	<b>G dia</b>
12.25 in. (311.2 mm)	7.00 in. (177.8 mm)	5.75 in. (146.0 mm)	4.00 in. (101.6 mm)	3.45 in. (87.6 mm)	1.50 in. (38.1 mm)	0.875 in. (22.2 mm)

## REPLACEMENT PARTS

<b>Component</b>	<b>Part Number</b>
Keypad	B260713
Battery	B280601
Battery Tie Wrap	B228036
Pickup Cable	B222-121
Desiccant Bag	B260630
PVC Union	B220016
PVC Reducer Bushing	B220056
Rubber Washer	B228207
Steel Lock Washer	B220018
PCB Shield (battery units)	B280603
Desiccant Shield	B280680
Cord Grip	B220103

# INSTALLATION DRAWING

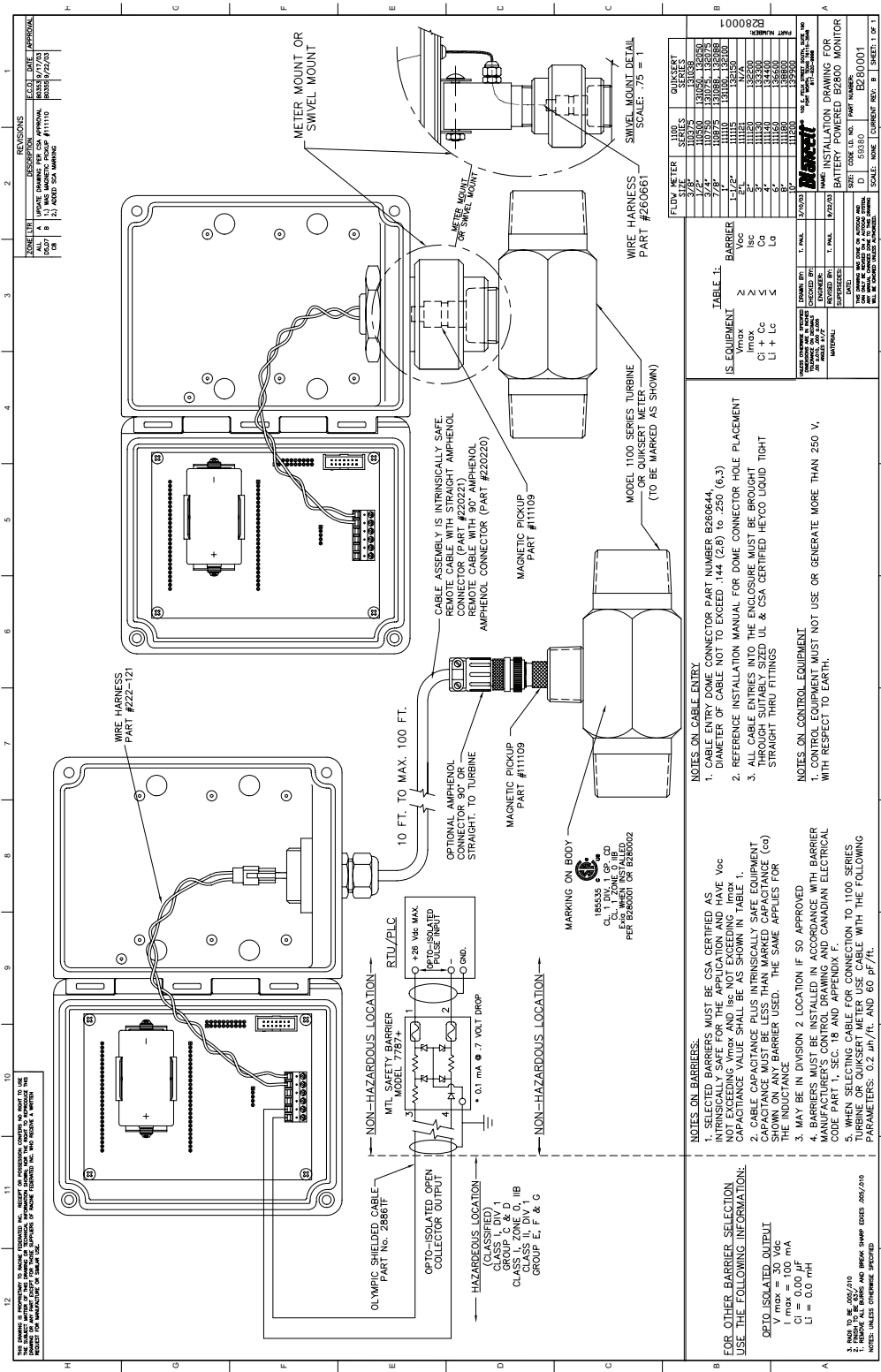

## Control. Manage. Optimize.

BLANCETT is a registered trademark of Badger Meter, Inc. Other trademarks appearing in this document are the property of their respective entities. Due to continuous research, product improvements and enhancements, Badger Meter reserves the right to change product or system specifications without notice, except to the extent an outstanding contractual obligation exists. © 2015 Badger Meter, Inc. All rights reserved.

**[www.badgermeter.com](http://www.badgermeter.com)**

---

**The Americas | Badger Meter** | 4545 West Brown Deer Rd | PO Box 245036 | Milwaukee, WI 53224-9536 | 800-876-3837 | 414-355-0400  
**México | Badger Meter de las Americas, S.A. de C.V.** | Pedro Luis Ogazón N°32 | Esq. Angelina N°24 | Colonia Guadalupe Inn | CP 01050 | México, DF | México | +52-55-5662-0882  
**Europe, Middle East and Africa | Badger Meter Europa GmbH** | Nurtinger Str 76 | 72639 Neuffen | Germany | +49-7025-9208-0  
**Europe, Middle East Branch Office | Badger Meter Europe** | PO Box 341442 | Dubai Silicon Oasis, Head Quarter Building, Wing C, Office #C209 | Dubai / UAE | +971-4-371 2503  
**Czech Republic | Badger Meter Czech Republic s.r.o.** | Mařikova 2082/26 | 621 00 Brno, Czech Republic | +420-5-41420411  
**Slovakia | Badger Meter Slovakia s.r.o.** | Racianska 109/B | 831 02 Bratislava, Slovakia | +421-2-44 63 83 01  
**Asia Pacific | Badger Meter** | 80 Marine Parade Rd | 21-06 Parkway Parade | Singapore 449269 | +65-63464836  
**China | Badger Meter** | 7-1202 | 99 Hangzhong Road | Minhang District | Shanghai | China 201101 | +86-21-5763 5412