



Model 1005
Pulse to DC Converter

**Installation, Operation
and Maintenance Manual**

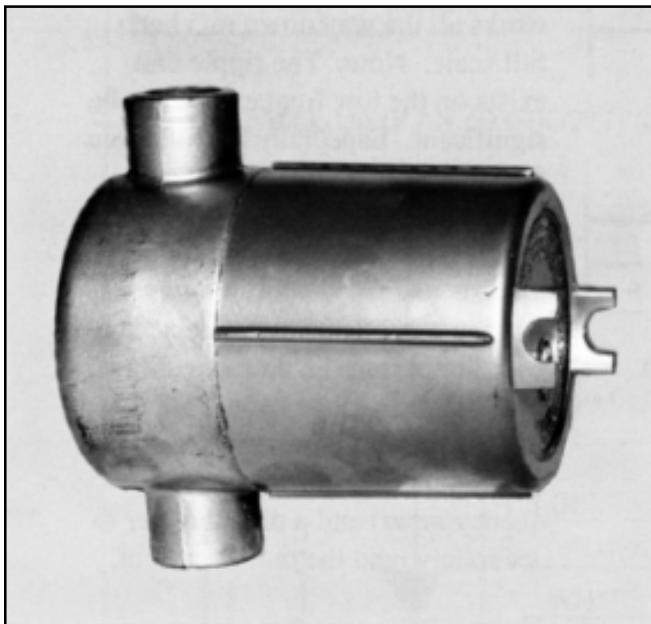

Table of Contents

General	1
Specifications	1
Installation	1
Theory of Operation	2
Setup	2
Jumper Locations	3
Input Circuit	3
Terminal Identifications	4
Input Wiring	4
Input Connections	5
Maintenance	5
Calibration	5
Hookup Diagram	6

Installation, Operation & Maintenance

GENERAL

The Model 1005 conditions pulses from a variety of liquid flow sensing devices to a 4-20 mA output signal which is proportional to the flow rate. The output is used to transmit flow rate over long distances with no loss of accuracy and to interface with chart recorders, computers, and other instrumentation.

SPECIFICATIONS

Repeatability: 0.1% of Full Scale

Linearity: 0.5% of Full Scale

Frequency Range: 5 to 5000 Hz

Inputs:

- Form A SPST Contact Closure
- Form C DPDT Contact Closure
- Optical Coupler (square wave)
- High Speed Pulse (10 to 15 V peak)
- Low Level Magnetic Pickup (sine wave)

Output: 4-20 mA, self powered into a maximum of 500 ohms

Power Requirements: 115 VAC, $\pm 10\%$ (less than 10VA required)

Enclosure: Metal enclosure with two 1" conduit connections; rated for Class I Groups C & D, Class II Groups E, F, & G, and Class III

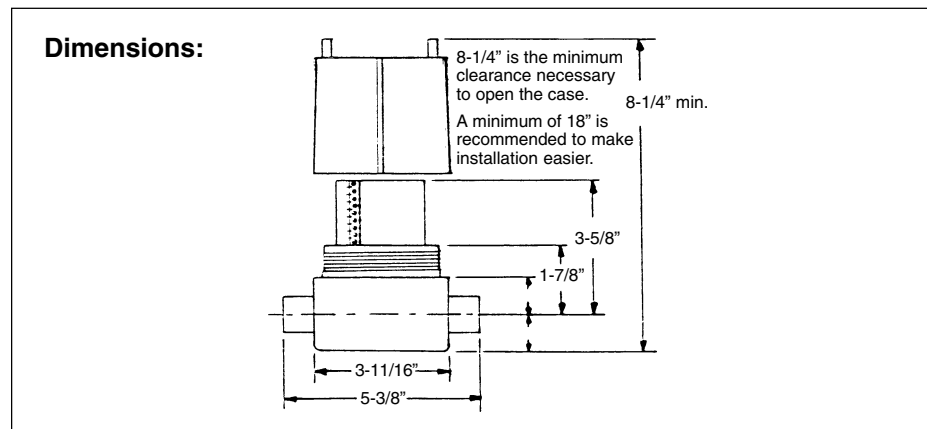

INSTALLATION

Incorrect wiring of this device may cause permanent damage.

The enclosure should be mounted before wiring the unit. It may be necessary to remove the PC board before pulling wires to the 1005.

Note: When inserting or removing the PC board, tilt the top edge away from the side of the board with the transformer. Otherwise, the brackets on the end of the board will not have enough clearance to get through the opening of the enclosure. Do not use force. It is not necessary.

All electrical connections are made at the terminal strip on the left side of the board. Power, an input and output, must be wired to the 1005. See Wiring Diagrams.

The power must be supplied by a 115 VAC source. It attaches to Terminals 8 & 9, with the power ground (earth or safety ground) attached to Terminal 7. **Note:** Terminal 7 is also tied to the case of the 1005. **Caution:** Power should not be run in the same conduit with any of the input or output signals. Because the other signals are low voltage, they might pick up enough noise from the AC power leads to cause significant errors.

The input must come from a meter with a pulse output. There are types of meter inputs that can be accepted by the 1005. The meter always goes to Terminal 4 and some combination of Terminals 3, 4, and 6. Examples can be found in the Input Wiring Diagrams. For the output, Terminal 2 is the positive supply (source) of the 4-20 mA output, and Terminal 1 is the return. Terminal 1 is also the circuit common (ground) for the 1005. Because the 1005 is an isolated unit, circuit ground can be tied to some voltage other than earth ground, if desired.

Under most conditions, the low voltage circuitry should be grounded at some point. If the 4-20 mA loop connects to circuitry that is grounded, it should be left floating. If the 1005 connects only to other floating circuitry, then the 1005 circuit common probably should be tied to ground. If there appears to be a noise problem with the 1005, you might try adding or deleting the connection between ground and circuit common.

Warning: Always be careful to avoid ground loops (circuit grounds of different instruments connected together through more than one circuit path), whether Terminal 1 is tied to earth ground or not. Ground loops can create significant errors.

THEORY OF OPERATION

The Model 1005 comes in three versions to handle different types of inputs. Most inputs are handled by the basic version.

The 1005 amplifies and conditions its input signal to create a sharp, clean square wave. The square wave becomes the input for a voltage-to-frequency (v/f) converter which has an analog voltage output. The signal is then used to control a 4-20 mA current source. The current output is proportional to the pulse rate of the input signal. It can be used with a local indicator or transmitted over long distances with little loss in accuracy.

The Model 1005 can be calibrated for a wide variety of frequency ranges. At the high end, the maximum is 5000 Hz full scale.

The 1005 has all of the components it needs to cover its full range. Scaling components are selected with jumpers at the time of calibration. All that is needed to calibrate the 1005 is an accurate signal source (to stimulate the maximum frequency input) and a digital meter to accurately read the output current.

Setup

The 1005 is set up at the factory according to the meter it will be working with. The only two items of concern when setting up the 1005 are the full scale frequency and the meter that interfaces with the 1005. If both were defined when the 1005 was purchased, or if the input meter was bought from Niagara, no setup work is needed. It was already completed at the factory. Setup and calibration are needed only if something is changed later within the system.

Model 1005 Pulse to DC Converter

The S4 jumper is the only setup item that cannot affect calibration. It changes the input characteristics of the 1005 providing a pull-up or pull-down for the input or slowing it down for a Form C input. The appropriate selection is made with S4 to match the needs of the meter input to 1005. The Input Wiring Diagrams show the most likely settings for each type of input. A schematic for the input circuitry can be found with the jumper locations. **Note:** Some inputs do not require any of the three choices of S4. If none are needed, it is recommended that the jumper be left on one terminal, with the other half of the jumper left hanging empty so that the jumper will not be lost if needed later. **Note:** The input should switch from below 3 volts to above 9 volts for the basic version of the 1005. If not, it may not work.

Jumper Locations

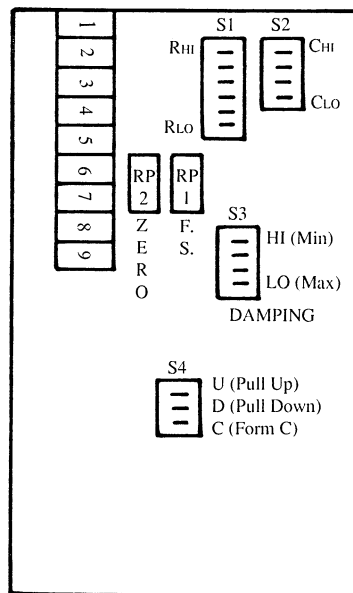

Input Circuit

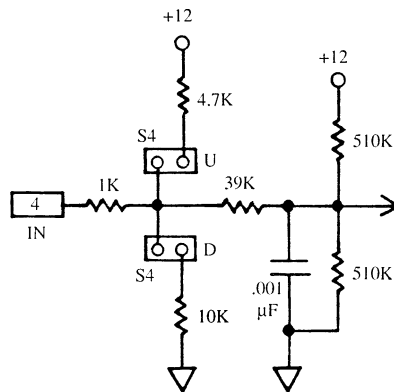

If desired, the user can change the response time of the meter by changing the damping (S3) jumper. It affects not only how fast the 1005 responds to the input, but also how much ripple exists on the output current. More damping means less ripple and a longer response time. Less damping means shorter response time but more ripple on the output. The 1005 is normally shipped with the damping jumper in the same relative position as the capacitor jumper. It is unlikely it should be moved more than one position from that setting.

“HI” Damping: Hi frequency only (the least amount of damping)

“LO” Damping: For low frequencies (and minimum ripple)

Time Constants:

Damping	Time Constant (approximate only)
Min (“Hi”)	.07 sec.; .3 sec.; 1.5 sec.
Max (“Lo”)	7 sec.

Terminal Identification

Gnd	1	Low voltage circuit common/ground
4-20	2	Output; Current source to Gnd; 4 mA out at 0 Hz in, 20 mA at full scale
Gnd	3	Low voltage circuit common/ground
In	4	Input pulse, relative to Gnd.
+12	5	+12 VDC supply voltage for devices needing external power
LED	6	750 ohms to Gnd; To LED cathode; For powering LED of photo sensor
Case Gnd	7	AC/safety ground
VAC	8	120 VAC power lead
VAC	9	120 VAC power lead

Input Wiring

Common to all units

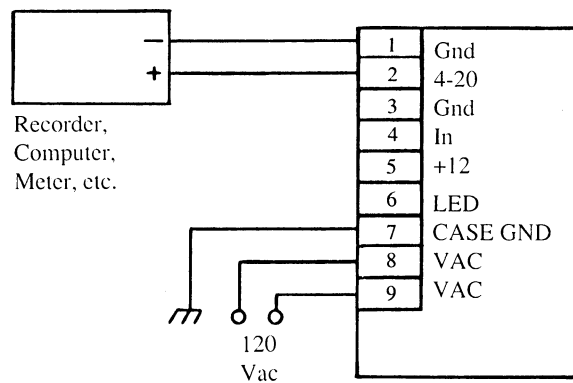

Form A
P/N 60380G275

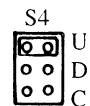
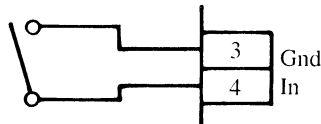

Form C
P/N 60380G275

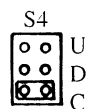
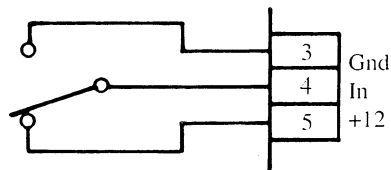

Model 1005 Pulse to DC Converter

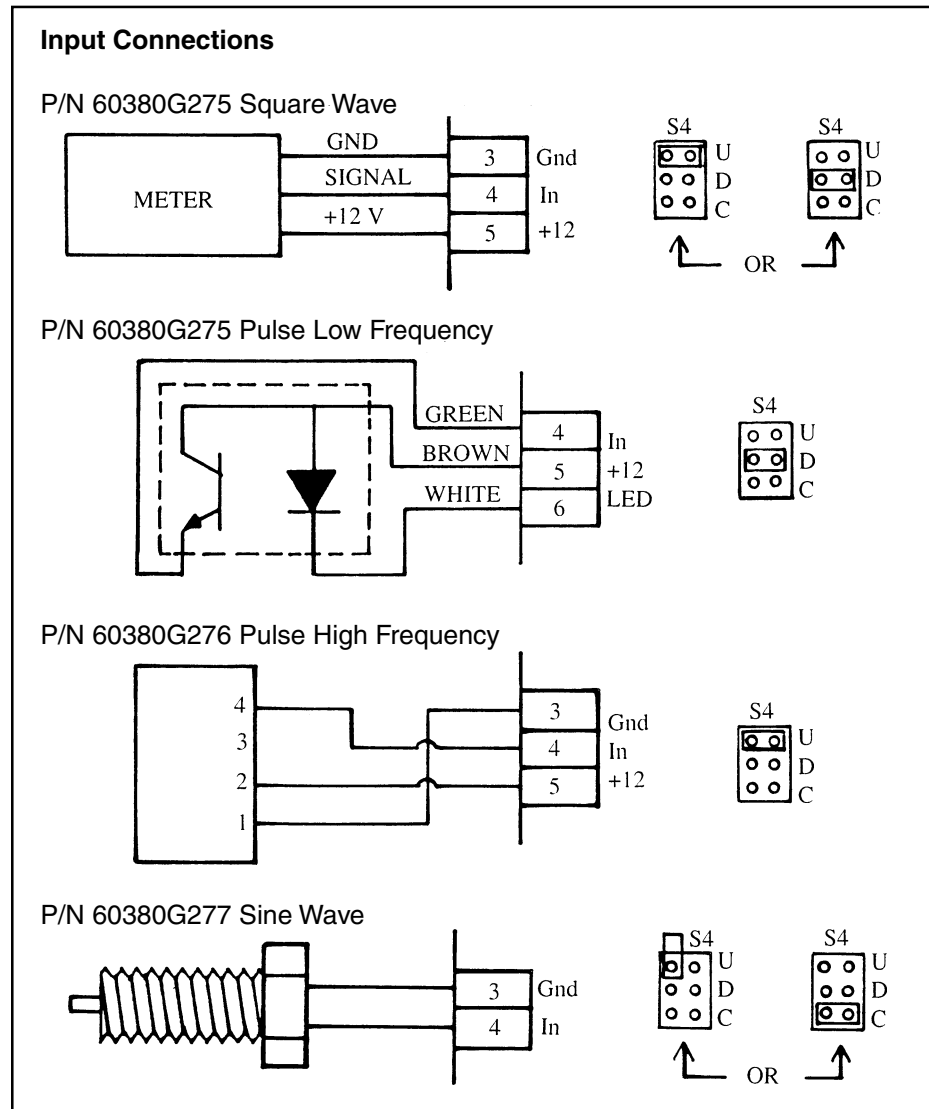

MAINTENANCE

Calibration

The meter calibration should not need adjusting when it is first installed. However, periodic checks are recommended for all measurement equipment.

I. Equipment Needed

Signal Generator, Frequency Counter, Digital Multi-meter (for reading DC volts and 4 to 20 mA)

II. Hookup (see diagram)

The signal generator output should be:

1. 0 to 12-15 V pulse for either the pulse or hi speed versions. (60122G207 and 60122G208)
2. 100 mV, AC coupled signal for the low level sine-wave input version. (60122G209)

III. Testing

When power is first applied, verify that the power supply is correct by checking the +12 V on the terminal block. Using the digital meter in voltage mode, connect to ground at Terminal 1 and measure Terminal 5 which should be +12 V \pm 0.5 V.

IV. Calibration

1. With no input (0 Hz), adjust RP2 for 4 mA out.
2. Turn RP1 full CW.
3. Using the signal generator, and measured with the frequency counter, input the maximum signal frequency. (This is the frequency that is to output 20 mA.)
4. Set the jumpers on S1 and S2 to CLO and RLO (the bottom positions), and the DAMP jumper (S3) to the bottom. **Note:** As the C jumper (S2) is moved one position, the DAMP jumper (S3) should be moved one position in the same direction, i.e., both up or both down.
5. Verify IOU is > 20 mA. If not, either the frequency is too low or something is wrong with the 1005.
6. Move the C jumper (S2) up one position and the DAMP jumper (S3) up one position.
7. If IOU is still > 20 mA and the C jumper (S2) is on CHI, go to step 9. Otherwise, repeat step 6.
8. Move the C jumper (S2) back down one position so the output is again > 20 mA.
9. Move the R jumper (S1) up one position.
10. If IOU is still > 20 mA and the R jumper (S1) is on RHI, go to step 12. Otherwise, repeat step 9.
11. Move the R jumper (S1) down one position so the output is again > 20 mA.
12. Adjust RP1 to get 20 mA out.
13. Remove the input to check 4 mA. If it has changed, adjust RP2 to get 4 mA. As needed, continue checking 4 and 20 mA, and adjusting RP2 and RP1, until no further adjustment is needed.

Hookup Diagram

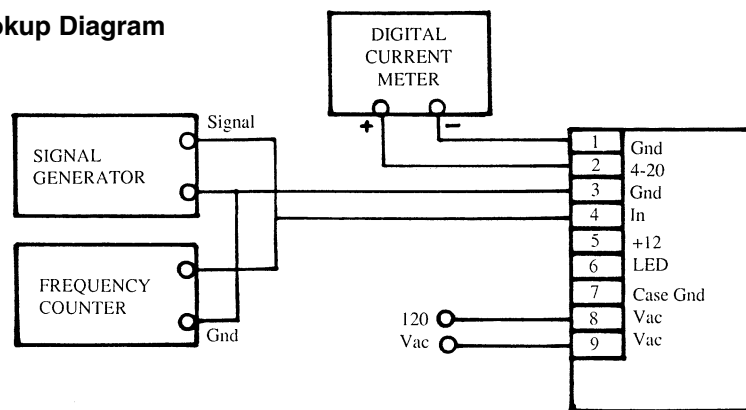

150 Venture Boulevard
Spartanburg, SC 29306

Phone: (800) 778-9251, (864) 574-3327
Fax: (864) 574-8063
Internet: www.aaliant.com
E-mail: sales@aaliant.com