



Model HPM Oscillating Piston Installation & Operation Manual





Model HPM Oscillating Piston Installation & Operation Manual

CONTENTS

I. HANDLING & STORAGE	1
Inspection and Handling	
Disposal and Recycling	
Storage	
II. GENERAL SAFETY	2
Authorized Personnel	
Use	
Misuse	
III. PRODUCT DESCRIPTION	3
Function	
Applications	
Features	
Technical Specifications	
Approvals	
IV. MECHANICAL INSTALLATION	5
Guidelines	
Mounting Considerations	
V. MAINTENANCE	6
Replacement Parts	
VI. TROUBLESHOOTING	7
VII. DIMENSIONAL DRAWINGS	9

SAFETY SYMBOLS



WARNING:

IDENTIFIES CONDITIONS OR PROCEDURES, WHICH IF NOT FOLLOWED, COULD RESULT IN SERIOUS INJURY. RISK OF ELECTRICAL SHOCK.



CAUTION:

IDENTIFIES CONDITIONS OR PROCEDURES, WHICH IF NOT FOLLOWED, COULD RESULT IN SERIOUS DAMAGE OR FAILURE OF THE EQUIPMENT.

Model HPM Oscillating Piston Meter Installation & Operation Manual

I. HANDLING AND STORAGE

SAVE THESE INSTRUCTIONS

INSPECTION AND HANDLING

Do not dispose of the carton or packing materials.

Each package should be inspected upon receipt for damage that may have occurred due to mishandling during shipping. If the unit is received damaged, notify the carrier or the factory for instructions. Failure to do so may void your warranty. If you have any problems or questions, consult Customer Support at (800) 778-9251 or (864) 574-3327.

DISPOSAL AND RECYCLING

This product can be recycled by specialized companies and must not be disposed of in a municipal collection site. If you do not have the means to dispose of properly, please contact Customer Support for return and disposal instructions or options.

STORAGE

If the device is not scheduled for immediate installation following delivery, the following steps should be observed:

1. Following inspection, repackage the unit into its original packaging.
2. Select a clean dry site, free of vibration, shock and impact hazards.
3. If storage will be extended longer than 30 days, the unit must be stored at temperatures between 32° and 158° F (0° to 70° C) in non-condensing atmosphere with humidity less than 85%.



CAUTION: DO NOT STORE A NON-POWERED UNIT OUTDOORS FOR A PROLONGED PERIOD.

II. GENERAL SAFETY

AUTHORIZED PERSONNEL

All instructions described in the document must be performed by authorized and qualified service personnel only. Before installing the unit, please read these instructions and familiarize yourself with the requirements and functions of the device. The required personal protective equipment must always be worn when servicing this device.

USE

The device is solely intended for use as described in this manual. Reliable operation is ensured only if the instrument is used according to the specifications described in this document. For safety and warranty reasons, use of accessory equipment not recommended by the manufacturer and any modification of this device is explicitly forbidden. All servicing of this equipment must be performed by qualified service personnel only. This device should be mounted in locations where it will not be subject to tampering by unauthorized personnel.

MISUSE

Improper use or installation of this device may cause the following:

- Personal injury or harm
- Application specific hazards such as vessel overflow
- Damage to the device or system

If any questions or problems arise during installation of this equipment, please contact Customer Support at (800) 778-9251 or (864) 574-3327.

III. PRODUCT DESCRIPTION

FUNCTION

The HPM measures virtually any liquid and handles flow rates from 7 to 150 gpm with excellent repeatability and sustained accuracy. The compact design allows installation in tight places and retrofits easily to existing applications. We also supply a complete line of registers and accessories to meet your specific requirements. It's not just another piston meter. The HPM meets or beats the competition in quality, specifications, and price — a comparable unit at this price simply cannot be found.

The piston is guided by the fixed diaphragm and rotating spindle. The spindle rotates in the channel between the roller and the inside chamber wall.

Figure 1. Title

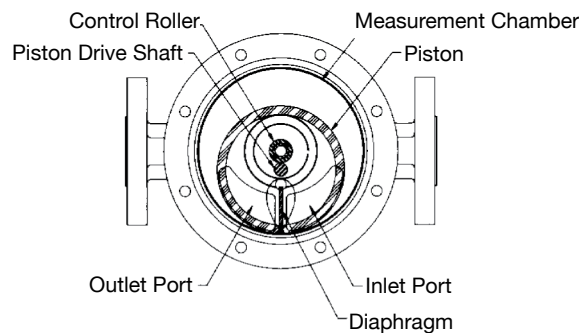

Note: "a" and "c" receive liquid from Inlet Port 1 and as the piston moves, "b" and "d" discharge liquid through Outlet Port 2

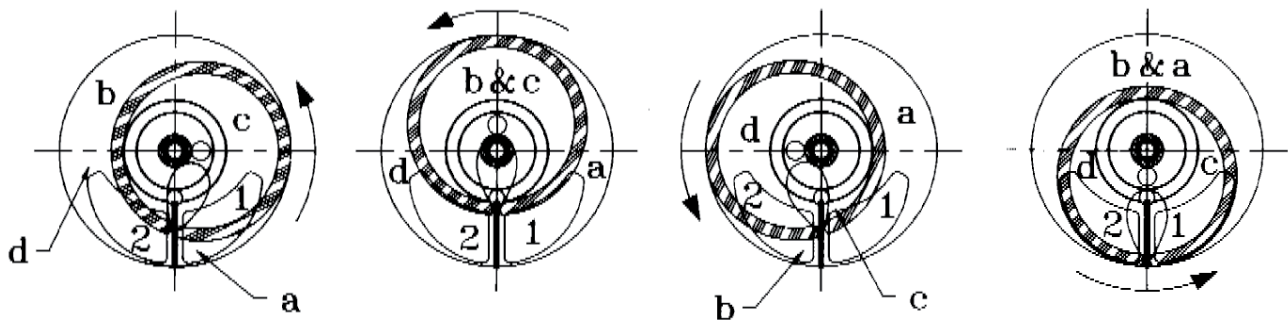

APPLICATIONS

- Chemical processing. Corrosive liquids like acids, emulsions, and toluene
- Industrial manufacturing. Adhesives, alcohol, coatings, fuel oil, wax emulsion
- Paint. Solvents and turpentine
- Pulp and paper. Acids, alcohols, brighteners, cleaners, coatings, varnishes, zinc, synthetic resins
- Food processing
- Concrete batching
- Cosmetic
- Pharmaceutical
- Agrichemical
- Automotive

FEATURES

- Available at a cost which enables you to standardize with stainless steel — at bronze prices
- Stock-able for immediate delivery
- Better flow range flexibility
- Insensitive to moderate viscosity changes
- Designed to provide a long life and trouble-free service

TECHNICAL SPECIFICATIONS

FUNCTIONAL

Fluid Types	Liquid
Maximum Pressure	275 psig (19 bar)
Fluid Temperature	32° to 150° F (0° to 66° C)
Registration	U.S. gallons/lbs/Imperial gallons/liters
Outputs	Mechanical totalizing, mechanical batching, electro-mechanical totalizing, electro-mechanical batching, and blind electronic pulse registers available. See specifications for registers.

PERFORMANCE

Accuracy	± 0.5% of rate
Repeatability	± 0.1% of rate
Flow Turndown Ratio	10:1
Flow Range	See Table 1

PHYSICAL

Materials of Construction	
Case	316 SS
Chamber	316 SS
Flanges	316 SS
Piston	ETFE
Seals	Teflon™ encapsulated silicon rubber
Register Housing	Plastic, Bronze, Aluminum. See specifications for registers.
Connections and Mountings	
Mounting Position	Horizontal. Ensure meter remains full with register up.
Typical Straight Pipe Requirements	Upstream 0 x D
Process Connections	Downstream 0 x D
Electrical Connections	ANSI Class 150 RF
	Only for optional electronic transmitter

IV. MECHANICAL INSTALLATION



WARNING: USE THE METER ONLY WITH THE LIQUID FOR WHICH IT WAS ORDERED AND WITHIN THE SPECIFIED LIMITS OF PRESSURE, TEMPERATURE AND FLOW RATE.

MOUNTING CONSIDERATIONS

- If fluid is prone to sediment, consider adding a trap strainer to the system - arranging the strainer so it can be easily cleaned. See Figure 2 as an example.
- In gravity-pressure installations, set the meter to take advantage of all possible pressure head.
- In pump-pressure installations, set the meter on the discharge side of the pump.
- If the line must be kept in continuous service, install a bypass around the meter and strainer valves being installed or replaced.

OSCILLATING PISTON INSTALLATION

1. Drain system, if in use.
2. Determine where the meter will be installed within the current system.
3. Cut the pipe (if applicable).
4. Install 60 mesh (0.009 in.) strainer. Strainer should be installed so it can easily be cleaned.
5. Connect meter couplings (if applicable).
6. Flush line thoroughly with liquid to remove pipe cuttings, chips, etc.
7. Install the meter and tighten into place.
8. Purge air from the line.
9. (Re)Fill system slowly to ensure no air is in the line. Meter is ready to take readings. Pipe must remain fully flooded at all times in order for the meter to take accurate readings; avoid passing air or vapor through the meter.

NOTE: To help keep air out, do not let the meter drain between periods of usage. Trap the meter in a depression in the pipeline if necessary. Keep suction lines and pump stuffing boxes tight. If air cannot be kept out of a line handling light oils or solvents, use an air release valve between the pump and meter.

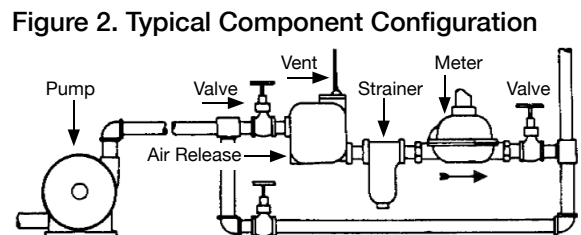

Figure 2. Typical Component Configuration

NOTE: The meter must be operated within its proper capacity range; it can be operated at the full rated capacity without damage.

V. MAINTENANCE

Inspect the unit periodically for worn parts due to natural water wear, corrosion or abrasion.

Strainer should be checked and cleaned regularly.

REPLACEMENT PARTS

PART NUMBER	DESCRIPTION
90073	Cap Screws
60003P060-1	1" Meter Cover/Lid
60003P061-1	2" Meter Cover/Lid
51596G038	Magnetic Drive Assembly
60150P013	Retainer Spring
60191P011	Seal Plate (1" Only)
60060P007	Seal Plate Screws (1" Only)
60331P007	1" O-Ring Case Seal
60331P008	2" O-Ring Case Seal
51010P002	Control Pivot (1" Only)
60494G007	1" Piston Assembly
60494G008	2" Piston Assembly
51010P001	1" Control Roller
51010P089	2" Control Roller
51032P069	1" Diaphragm
51032P070	2" Diaphragm
60493P001-1	1" Meter Body
60493P002-1	2" Meter Body
60494G009	1" Piston Kit (Includes Piston Assembly, Control Roller and Diaphragm)
60494G010	2" Piston Kit (Includes Piston Assembly, Control Roller and Diaphragm)
51335P041	Plastic Adapter

VI. TROUBLESHOOTING

Repairs or replacement of parts may affect the accuracy of the meter.

SYMPTOM	POSSIBLE CAUSE	SOLUTION
Meter stops	Liquid is no longer flowing through the pipe	Check all systems for flow of liquid, including valves ahead of the meter in the pipe line
		Remove the register box or lift a vertical register off its seat and see whether the drive shaft passing upward from the meter body turns when liquid is flowing. If the drive shaft turns, the trouble is in the register; if it does not turn, the issue is inside the meter.
Register is issue - after drive shaft test		Tighten set screw of all the change (calibrating) gears
Meter is issue - after drive shaft test		Clean unit - see Maintenance section for detailed instructions
Consistent inaccuracy (less than 5%)	Error in original calibration, wear, change in liquid viscosity	Call factory
Over-registers (erratically)	Air, steam or gas is in the line with the liquid	Remove air, steam or gas; install an air release valve ahead of the meter
Under-registers (erratically)	Severe wear or clogged pipe	Check to see if any debris is in the line
Dial hand stops and jumps ahead	Difficulty with the meshing of the gearing, usually in the change gears.	Adjust the change gears so they mesh smoothly with just enough clearance to prevent binding and replace worn gears.
Leakage of metered liquid - around the meter body	Operating pressure is above that which the o-ring was intended	Reduce pressure
	Temperature is too high for the o-ring	Reduce temperature or change out meter to match application
No flow indication when flow exists	Meter bypass lines are not closed	Close bypass lines
	Mechanical register may have seized due to freezing	Check lines and temperatures
	Defective register	Call factory
	Defective magnetic drive assembly inside meter	Call factory
Reduced or nonexistent fluid discharge	Leaky valves in bypass line	Check and/or fix bypass lines
	Blocked or frozen strainer	Remove debris; warm to unfreeze
	Debris inside flowmeter causing sticking	Remove debris
	Worn control roller, diaphragm plate or piston in flowmeter	Replace worn parts
	Damaged/rough interior meter surfaces due to dirt or grit in flow medium	Add strainers to remove debris; replace damaged parts as needed
Leakage at meter casing/lid	Loose bolts	Tighten bolts
	Damaged O-ring due to excessive pressure	Replace o-ring; check and/or reduce pressure in line
	Debris between O-ring and sealing surfaces	Replace o-ring
Inconsistent over-registration	Air or gas in fluid	Purge line

Inconsistent under-registration	Leakage around flowmeter due to bypass piping	Check piping seals, add as needed
	Badly worn flowmeter internals	Replace parts as needed
	Damaged flowmeter casing	Call factory
	Debris in measuring chamber	Remove debris
	Suspended solids in fluid medium too large	Add strainers to remove solids
Consistent over or under-registration	Flowmeter in need of calibration	Call factory

Contact your local factory representative if additional assistance is needed. Please provide the following information:

- Model number
- Date of Purchase
- Application information (type of material, mounting configuration, etc.)
- Description of problem

If your local representative is unable to determine the cause of difficulty, you will be referred to a factory engineer. Equipment shipped back to the factory without proper authorization will be refused and returned at the shipper's expense.

VIII. DIMENSIONAL DRAWINGS

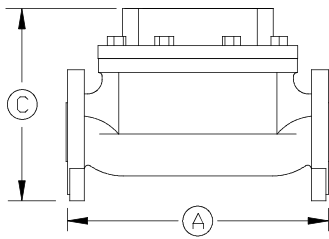

METER DIMENSIONS - IN INCHES

A	B	C	D
9.00	6.88	6.56	ANSI 1" 150 lb Class
13.00	9.38	7.25	ANSI 2" 150 lb Class

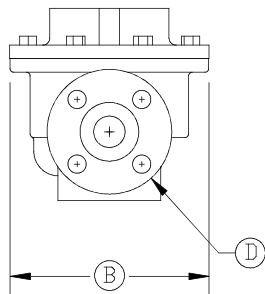

Notes

Notes



150 Venture Boulevard
Spartanburg, SC 29306
Tel: (800) 778-9251
Tel: (864) 574-3327
Fax: (864) 574-8063
sales@niagarameters.com
www.niagarameters.com

venture
MEASUREMENT

2013 All rights reserved.
All data subject to change without notice.

M115 Rev. D